

OUROBOROS



This manual, specifications and features of the Ouroboros Rebreather are proprietary and copyright Closed Circuit Research Ltd, 2003-2004.

This document cannot be copied or distributed without the prior agreement and authorization from Closed Circuit Research Ltd.

All information contained is subject to change. Contact the manufacturer for the latest information. www.ccrb.co.uk

The Ouroboros rebreather is manufactured in the UK by Closed Circuit Research Ltd. Unit 12. Black Hill Rd West. Holton Heath Industrial Estate. Poole. Dorset BH 16 6LU. Tel. +44 1202 624478.

EC Type approved by SGS UK Ltd. Weston-super-Mare. BS22 6WA. Notified Body No. 0120.

Testing conducted by ANSTI Test Systems. Hants.

The Ouroboros is pending CE approved to 40m using air as a diluent and 100m using Heliox 9/91 meeting the requirements of EN14143:2003. Accreditation will complete in January 2005.

OUROBOROS

Ouroboros Underwater Closed Circuit Rebreather Systems Manual

Contents

Using this manual	6
Warnings	7
Rebreather fundamentals	8
Unit Layout	9
Post shipping set-up	10
Finding leaks	11
Negative tests.....	11
Immersion tests	11
Adjusting the stainless steel LP fittings	12
Weighting	13
Harness Positioning	13
Bailout cylinders and off-board gas	13
Pre-dive set-up	14
Filling the gas supply cylinders.....	15
Gas endurance.....	15
Filling the absorbent canister	15
Changing batteries	18
Backup PO2 Display use.....	19
Calibration	20
Oxygen sensor tests.....	20
On screen Pre-dive checks	22
Pre-dive Checks Table.....	23
Turn on rules	26
Diving Skills	27
Leak testing	27
Calibration	27
Harness Adjustment	27
Buoyancy Control	27
Open circuit bailout.....	27
Manual flight	27
Oxygen solenoid and ADV failure modes	28
Oxygen/diluent flow rate demonstrations	28
Diluent flushes.....	28
Flood Recovery	29
Bailout and ascents	29
Oxygen sensor isolation	29
Off-board gas selection	30
Electronic bailouts	30

OUROBOROS

Ouroboros Rebreather Primary and Heads-up Display Menu System	31
Introduction	31
Primary Display. Left and right switch presses	33
Pressing both switches together	33
Screen list	34
Main Dry Screen.....	35
Main Dry Screen-Saver	37
Main Dive Screen	38
Dive Screen Alarm Conditions	39
Dive Screen Alarm Conditions - continued	40
Dive Screen Display Features	41
Main Dive Screen-Saver	43
Turn On screen	44
Open/Closed and PO2 select screen	45
Gas Select Screen	46
Gas Adjust Screen	47
Enabled Diluent and open circuit gases.....	47
O2 sensor Screen	48
O2 sensor Calibrate Screen	49
Calibration Gas	50
Atmospheric Adjustment.....	50
O2 Sensor Polling.....	51
Dvo Screen	52
Dvo Screen - Advanced	53
HP / Stack screen.....	55
Decompression Screen Summary.....	56
Sum - Summary screen.....	57
Sum – Summary screen Alarms Tables	58
PPO2 Alarm Table – Highest Priority 1.....	58
Valve Alarm Table – Priority 2	58
Stack Alarm Table – Priority 3	59
Battery Alarm Table – Priority 4.....	59
High Pressure HP Diluent and Oxygen Alarm Table – Priority 5	59
Decompression Alarm Table – Priority 6	60
Ascent Rate Alarm Table – Priority 7.....	60
O2 Cell Alarm Table – Priority 8	60
Pre-Dive Alarm Table – Priority 9	60
Ouroboros General Description and Background	63
History	63
Overview of closed circuit rebreather components.....	66
Improvements incorporated in Ouroboros	66
Ouroboros Mechanical Systems	68
Design Criteria.....	68
1. Reliability	68
2. Breathing Performance and Pathways	68
3. Maintenance	70
4. Simplicity of Operation	70
5. Modularity and Flexibility in operation.....	71
Rebreather Component Layout	72

OUROBOROS

System Block Diagram – High Pressure/Medium pressure Gas piping.....	73
Ouroboros Electronics and Computer systems.....	74
Design Criteria.....	74
1. Safety/Reliability	74
2. Redundancy.....	75
3. Maintenance / Serviceability	75
4. Modularity	75
5. Upgradeability.....	75
6. Reprogram-ability and PC interface.....	75
Software and Electronics key functional points	76
Main sub-systems	77
Table of Heads Up Display (HUD) Alarms.....	81
System Block Diagram – Electronic System.....	84
Failsafe of oxygen addition valve.....	85
Re-programming system	87
Ouroboros PC Link for Dive Downloading and System Configuration.....	88
Installation	88
Operation	89
Import Rebreather.....	90
Download Dives.....	91
Import Text File.....	93
View Dives	94
Dive List.....	94
Main Dive Viewing Screen.....	95
Dive Details.....	97
Utility.....	98
Maintenance	99
Storage.....	99
Electronics routine maintenance and assembly	99
Component breakdown	101
Pipe work	103
Adjusting the ADV	103
O-Ring care.....	104
Oxygen sensor care	105
Disinfecting.....	106
CO2 absorbent storage	107
Repairing counterlungs	107
Appendix 1 - Safety Design Criteria	108
Appendix 2 –Programmable Systems.....	113
Appendix 3 - Shipping	114
Software Implementation	115
Software Processes.....	116
Vision Test.....	117
Glossary of Terms	118
Warranty	119

OUROBOROS

Ouroboros Rebreather General Specification	120
Index	124

OUROBOROS

Using this manual

Quick references (Hyperlinks) to other areas of the electronic manual are highlighted in [blue and underlined](#). Clicking on the link will jump to that reference. To return to the original page use the back arrow – this is often the left green arrow in the top left of your screen in the third tool bar down. For the printed version, page numbers are also referenced.

**Instructions which must be followed are
encapsulated in a warning box like this one.
Failure to adhere to them
may cause injury or death.**

Warnings

All diving carries with it risk of injury or death.

Rebreathers in particular can produce a range of gas poisoning which at first may not be apparent and may lead to confusion, panic, unconsciousness and death.

Hazards include but are not limited to;

Hyperoxia

Hypoxia

Hypercapnia

Airway and lung damage due to absorbent ingestion

Drowning

It is mandatory that all pre-dive checks are carried out prior to diving to help prevent any of the above occurring.

As diving is a dynamic event, pre-dive checks are only part of the vigilance required to conduct a safe rebreather dive. Control systems and displays should be regularly monitored and skills practiced as per your relevant training agency.

Care should be taken with maintenance and suitable open circuit bailout carried at all times in line with your training agencies requirements.

It is vital that correct, recognized training is undertaken prior to using this equipment. Such agencies include IANTD, TDI and others that have submitted approved training documentation.

While many of the problems you can encounter with a rebreather are covered in this manual, it is not definitive. It is important that you take time to review it.

This product and any accessories are only sold on the understanding that all warranty and liability issues are only covered under English Law, irrespective of where it was purchased or used.

OUROBOROS

Rebreather fundamentals

Read and understand this prior to using this unit. **If you do not understand any or all of this section please contact your training agency or Closed Circuit Research Ltd as appropriate.**

Rules for Rebreather Diving

1. Always do all pre-dive checks.
2. Always pre-breathe the canister.
3. Do not use a full-face mask which is not designed for a rebreather.
4. Always know your PO₂.
5. Never dive a unit you suspect is leaking.
6. Be especially diligent close to and on the surface where the PO₂ is potentially lowest.
7. Never leave your mouthpiece open on the surface.
8. Never use a pure gas in the diluent cylinder. The diluent should be breathable at all parts of the dive.
9. Take time to adjust your weight correctly, do not dive over-weighted.
10. Have two sources of buoyancy and buoyancy inflation.
11. Practice a skill on every dive.
12. Avoid unnecessary mask clearing.
13. Regularly disinfect the unit.
14. Never dive a re-packed canister.
15. Never hold your breath during an ascent
16. Do not dive with a low battery alarm.
17. Change all batteries at the same time.

If in doubt, bailout!!!

OUROBOROS

Unit Layout

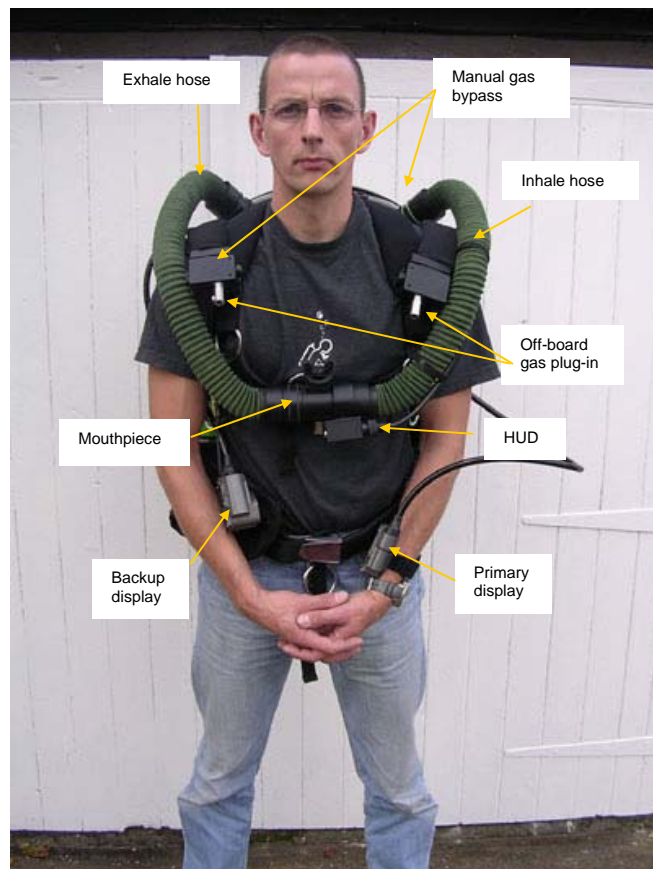

OUROBOROS

Post shipping set-up



Your rebreather will come shipped in a fully assembled state with the exception of the hose and mouthpiece assembly, which will be in a separate bag.

Although this rebreather is fully tested at the factory it is important to check for transport damage before conducting the pre-dive checks and undertaking any diving

Note

All hose and counter-lung fittings use dual radial O-rings. It is not necessary to over-tighten the fittings. Over-tightening the fittings may result in damage.

The following is a checklist of items, which may require attention and the relevant action.

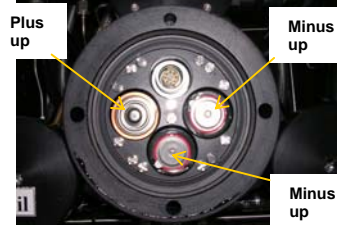
Item	Action	Picture/page reference
Mouthpiece	Check location of mushroom valves and function	
Hoses	Check all hose end O rings are in place	
Electronic Pod	Check battery levels and replace as required Page 18	
Leak test all LP and HP lines	Immersion test in water with gas turned on	Page 11
Disinfect	Clean breathing circuit before use	Page 106
Harness	Check it is secured to the back plate	
Wing	Check for leaks	

Finding leaks

Leaks may occur for several reasons, the failure of a part, miss-placed parts, transit damage or the ingress of dust and dirt.

Although the rebreather is highly tolerant of water ingress due to its ability to remove moisture from the breathing circuit whilst diving, you should never dive with known leaks in the system. If you suspect a leak, fix it first.

You should never dive with known leaks in the system. If you suspect a leak, fix it first.

Individual components should be tested in the following sequence.

As in the [pre-dive](#) test sequence (page 22) the primary test to define loop integrity is a negative pressure test. This is because of the positive over-pressure valve in the exhale counter-lung. A negative test will seal this valve, whereas a positive test will only inflate the counter-lung until the valve vents, and hence loop integrity is difficult to assess.

Negative tests

To perform the negative test, evacuate the loop. Open the mouthpiece straight away and listen for the 'suck' noise. Evacuate the loop again, taking note of the compressed state of the counter-lungs and hoses. Leave the unit for 5 minutes then look at the counter-lungs and hoses and make sure they are in the same state as before, in addition open the loop again and you should hear the same level of noise.

Immersion tests

If you suspect a leak, next start by immersing the complete unit with the loop full of gas. A small amount of gas venting will occur from the counter-lung exhaust valve. This will stop after a short while and allow you to look for any leaks in the remaining system. **Make sure you also immerse the manual bypass gas blocks and the mouthpiece.**

If a leak is not readily apparent, start by testing individual components.

1. Mouthpiece and hoses
 - a. Remove the assembled mouthpiece and hoses from the rebreather. Immerse the mouthpiece and hose ends, blow into the inhale hose end while blocking the exhale hose end with the mouthpiece closed. Immerse the mouthpiece. As the mouthpiece shutoff design is an O ring-less one, with excessive pressure some bubbles may be apparent. 300mb is the maximum recommended test pressure. If you think the mouthpiece is leaking follow the maintenance instructions on [page 101](#).
2. The counter-lungs

OUROBOROS

- a. Remove both counter-lungs. Attach the mouthpiece and hoses to one counter-lung. Immerse and inflate each counter-lung in turn. Look for leaks. The exhale counter-lung has an overpressure valve. This will vent at approximately 38mb and stop if the counter-lung is held at a constant pressure/depth. Look for leaks at the interface with the hoses and along the seams of the counter-lungs.
- b. The counter-lungs are fully encased and protected. However, in the unlikely event of a counter-lung becoming damaged with use, minor punctures can be repaired with the optional [repair](#) kit.



3. The dome and center section

- a. Having confirmed that the hoses and counter-lungs are sealed, these should then be attached to the center section and the dome installed. This should be done with the center section and dome out of the unit. Next attach the optional test hose (opposite) between the ADV inlet and the Oxygen inlet on the center section. These fittings should only be hand tight, no tools are required. Ensure the O rings are in place on the center section fittings.



- b. Inflate and immerse the complete assembly and look for leaks.

4. The low pressure (LP) pipe work

- a. With the counter-lungs and hoses fully assembled again, attach the cylinders and pressurise the system. Immerse the complete unit and use the manual bypass buttons to fill the counter-lungs. Look for leaks.

Adjusting the stainless steel LP fittings

If a leak is apparent at one of the end fittings on any of the stainless pipe work then it can be easily adjusted using a spanner/wrench. Depressurise the system, ensure you hold the fitting with a spanner/wrench and tighten the leaking nut with another spanner/wrench. Start by tightening the nut the equivalent of One hour on a clock face. Re-pressurize the system and check again as in 4 above.

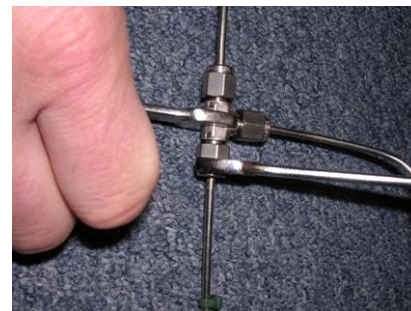

The system is designed such that even with a loose fitting the pipe will not come out of the fitting even though a leak may occur.

Weighting

As the counter-lungs inflate the diver may experience a movement in the rebreather. This is minimized by tightening the harness or adding counter-lung weights.

If the rebreather is allowed to move on the divers back, a change in breathing resistance may be noted. With back mounted units it is important that the counter-lungs are as close to the divers back as possible.

The rebreather has an optional counter-lung weight pouch. Small lead weights, lead shot and even sand and rocks can be used in the pouch.

Dependant on your physical size and diving suit/underwear configuration the rebreather should need little or no additional weights.

It is important to perform weight checks in confined shallow water with minimum levels of bailout gas prior to any open water diving.

Harness Positioning

When adjusting the harness try and imagine that the centre of the counter-lungs should be with +/- 100mm of the tip of your sternum (picture below) to give an optimum breathing performance. While the harness must be comfortable it should not be loose. The harness will sit differently on land when compared to when you are in the water.



Bailout cylinders and off-board gas

While the exact gas requirements for any type of diving are a matter of personal choice based on your rebreather certification and training agency, it is vital that a breathable open circuit bailout is carried at all times and for all depths of the dive.

OUROBOROS

It is vital that a breathable open circuit bailout is carried at all times and for all depths of the dive.

Due to the insipient nature of rebreather problems, it is recommended that the bailout regulator second stage is positioned around the neck on a rubber necktie. **An analysis of incidents has shown that bailout second stages positioned farther away than this are difficult to reach in a stressful situation.**

Bailout gas volumes should be calculated based on the depth of the dive and the ascent gas requirements. Cylinders can be positioned on D ring attachment points on the harness.

Counter-lung volume

The volume of gas in the counter-lungs will affect the 'breathing feel' of the unit. Too little gas will make inhaling difficult and too much will make exhaling difficult. All rebreathers have optimal positions in the water where they have a better or worse breathing feel due the hydrostatic affects of depth and the breathable volume in the counter-lungs.

It is important to balance the volume in the breathing loop so that excessive inhale or exhale pressure is not experienced.

Excessive pressure will also mean gas is possibly vented during the exhaled breath. This will result in a drop in oxygen levels and gas wastage.

While the rebreather has an automatic diluent addition valve (ADV), which compensates for loss of gas volume, as this is adjustable (and especially with new users) it is still possible to over inflate the breathing loop. To get an indication of the ideal loop volume you will be instructed to use the rebreather during your course with the ADV disabled. This will allow you to manually adjust for the optimum loop volume.

ADV Adjusting

The ADV is factory set to comply with CE requirements and should not need adjusting. However the ADV can be user adjusted. Procedures for [adjustment](#) are covered in the [maintenance](#) section on page 99.

Pre-dive set-up

Having assembled and tested the unit upon receipt it is important that all pre-dive tests are conducted prior to diving.

While the rebreather has a set of pre-dive checks built into the electronics, which prompt the diver to test certain aspects of the unit prior to diving, there are several manual tasks which should be completed prior to this final system check. These are:

Filling the gas supply cylinders

The oxygen and diluent cylinder valves are colour coded (oxygen has a green hand wheel on the valve). The oxygen cylinder will also only fit onto the diver's right hand side of the back plate. The maximum fill pressure of the cylinders is 232 Bar and should be done by a qualified technician. Install the oxygen cylinder into the right hand slider plate and push it all the way in until it 'clicks' and locks in position. Now install the DIN connection. Repeat for the diluent cylinder.

If you suspect that the cylinders have become contaminated with salt (especially the oxygen one) then you must get the cylinders inspected and cleaned as appropriate.

High pressure gas cylinders (**especially oxygen ones**) must have their cylinder valves opened slowly to avoid risk of injury.

Gas endurance

Gas endurance is defined by the Oxygen supply cylinders.

With the cylinder pressurised to 232 bar and assuming a usable gas pressure of the working pressure (232 bar) minus the regulator interstage pressure of 11 bar this equates to 221 bar available.

Assuming a CO₂ generation of 1.6l/min hence an oxygen consumption of 1.77l/min. The set will last a maximum of:

221 bar x 2L (supply cylinder WC) = 442 liters available.

@ 1.77l/m consumption the set will last:

442 divided by 1.77l/min equals 249.7 minutes or 4 hours and 9 minutes.

This duration is also dependent on how much loop venting occurs and is based on an excessive work rate.

As both the oxygen and diluent supply can be supplemented with additional gas via the Gas Block the set duration can be easily increased or added to should excessive use of diluent or oxygen occur.

Filling the absorbent canister

The unit has been tested under CE requirements for CO₂ absorbent canister duration. **The weight of absorbent in the Canister is approximately 2.7kg.** The test results are as follows;

At 40m of depth, with air as a diluent at 4 degrees centigrade water temperature with a CO₂ injection rate of 1.6l/minute and a ventilation (breathing rate) of 40l/min and a 2.7kg absorbent load of Sofnalime 797, the unit will last 154 minutes. At 15m this increases to 210 minutes.

OUROBOROS

These tests were conducted using Sofnalime 797 grade and durations can only be duplicated using this grade. If you use the colour-changing version of this absorbent do not rely in the colour indicator being a measure of use.

Tests conclude that depth and hence gas density; temperature and CO2 generation all massively affect absorbent duration. The Ouroboros rebreather employs a highly efficient radial canister design which not only gives greatly extended durations when compared to axial designs employing a similar absorbent load, but it is less affected by the commonly experienced high loss of efficiency associated with increased depth.

This is obviously an extreme test and axial canister designs, which use a comparable load of absorbent, have been found in trials to be generally 20% less efficient.

Safety data on Sofnalime products can be found at:

<http://www.molecularproducts.co.uk/v2/products/sofnolime/sofnolime.pdf>

Filling steps

1. Remove all the O-rings from the canister of which there are 3. Look for damage and replace as required.

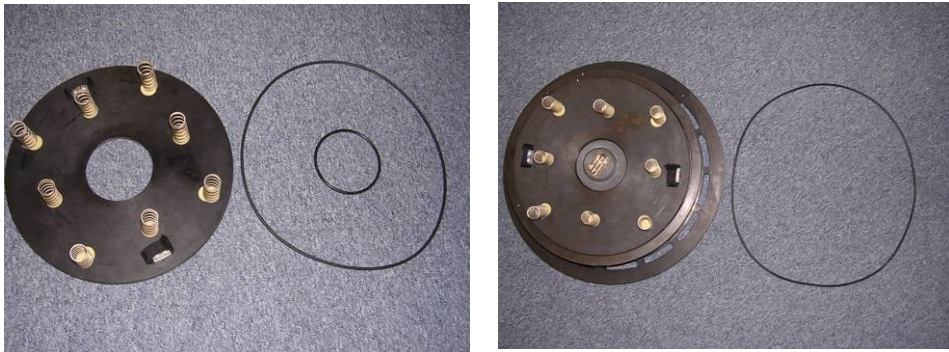

2. Clean and lightly grease the O rings with oxygen compatible grease.
3. Clean all the O rings grooves in the canister components.
3. Remove any excess Sofnalime stains from the canister components with warm, soapy water and then rinse in fresh water. Allow to dry.

All O-rings should be replaced at the 200-hour or Bi-annual factory service which ever is the sooner.

4. Fill the canister in a well-ventilated environment. Raise the Sofnalime barrel at least 200mm above the canister to allow dust to blow away as you fill. Fill to the line on the inside edge of the canister, making sure Sofnalime is at an even depth across the canister.
5. Ensure the canister is properly packed by tapping the sides as required and refilling periodically.
6. Wipe any dust from the canister.
7. Refit the O-rings.
8. Screw down the top.

OUROBOROS

9. You will be prompted to 'Zero' the canister duration timer during the [pre-dive checks](#) (page 22).
10. Dispose of old absorbent in the normal house hold waste. Do not leave it lying around for animals to ingest.

OUROBOROS

If you remove the canister between dives you must label it with your name and the amount of time used to date. See page 107 for [canister storage](#) information.



Having completed the above, the dome, hoses and counter-lungs can be replaced. The O rings in the middle and around the outside of the center section should also be checked as above and the [leak checks](#) (page 11) performed as discussed. You are now ready to start the pre-dive checks.

Changing batteries

Once a low battery alarm has been seen, all batteries in both the Main Electronics and the Backup Display should be changed together. The 3 Main Electronics batteries are located in the Electronics Pod which is accessed by unscrewing the Lock Ring around the Rear Facing PO2 display.



1. First remove all moisture from around the display and Lock Ring.
2. Unscrew the Lock Ring counter clockwise.
3. Gently pull the lid off (do not rotate it) or place a small coin under the lip and lever it off.
4. Wipe excess moisture off the clear lid and from around the batteries.
5. Note orientation of the cells.
6. Clean the O-ring and grooves and apply a small amount of grease to the O-rings. These are the only O-rings where you can use ordinary silicone grease.
7. Replace the batteries, [noting the orientation](#) page 10.
8. Line up the Electronics Pod Rear Facing Display pin with the locating hole in the Pod battery compartment.
9. Put the Lock Ring over the display and rotate a small amount counterclockwise until you hear a click, then turn clockwise until the thread engages.
10. Now push down squarely on the display until you feel the O-ring seat while turning the lock ring clockwise.
11. The display is fully engaged when you can feel no thread underneath the lock ring.
12. **Do not over-tighten the lock ring.**

OUROBOROS

At this point the displays will flash and the Primary Display will eventually go into the Time Set screen. The PO2 will be displayed on the rear screen. **If the rear display or HUD appear to freeze, remove the Pod cap and check battery orientation and then try and re-fit again.**

If no information is apparent on the Primary but the HUD and read facing display are present, then do a long hold of both buttons on the Primary and it will start-up.

Having replaced the batteries all dive log data is lost **and you must recalibrate the unit again before diving.**

Backup Display Battery

When the Backup Display battery needs changing the red LED will stay on permanently at the top of the Backup Display screen.

Unscrew the battery compartment in the Backup Display. Check, clean and re-grease the O-rings with silicone grease.

Replace the battery with the +ve end inwards. **For best results use a 3.6v lithium battery.**

Push the top button to display the PO2 and make sure the red light is off and the units turns off automatically (the red light will appear just as it is about to turn off, this is normal).

Backup PO2 Display use

The rebreather has a totally independent oxygen monitoring system with one display for each oxygen cell. All three are mounted in the Backup Display housing. This unit also has an independent battery compartment and three calibration potentiometers, one for each sensor. These potentiometers are located under waterproof covers on the rear of the display.

The top button on the display when pushed displays the PO2 of each cell.

The bottom and top buttons when pushed together display the milli-volt reading from each cell.

To see if the oxygen cells are nearing the end of their life, push and hold both buttons while exposing the sensors to air. They must read greater than seven milli-volts.

Do not use a cell with a reading in air of less than seven milli-volts.

This information is also shown on the [SUM](#) screen.

OUROBOROS

Calibration

It is not necessary to calibrate the unit prior to every dive but it is vital to do a pre-dive calibration check. When prompted to do so in the [Pre-dive](#) check screen (page 22), complete the following.

1. Make sure the diluent cylinder via the ADV cannot add gas into the loop.
2. Evacuate the loop and close the mouthpiece.
3. Fill the loop with oxygen until the over pressure valve just releases.
4. Without adding exhaled air into the loop evacuate it again.
5. Fill and evacuate again twice, leaving the loop full of oxygen at the third fill.
6. Follow the [on screen](#) instructions.
7. **Quickly open and close the mouthpiece to equalize the pressure** in the loop with the surrounding ambient pressure.
8. Check the Backup display (photo) and recalibrate as required.
9. Check the Primary display and confirm the PO₂ is correct on all 3 sensors to within 0.05 of the ambient PO₂ with 100% oxygen.
10. If the PO₂ is not correct, go to the [GAS screen](#) (page 47) and select Oxygen as the calibration gas. Now [calibrate](#) the unit.
11. Flush once more with oxygen and confirm the readings.
12. If the readings are still wrong you must abort the Pre-dive checks and open the Dome and expose the sensors to atmospheric air for 5 minutes. Now select the milli-volt function on the Backup display by pushing both buttons together. If any of the cells are below 7mv they need replacing.
13. Before replacing the cells remove and clean the jackplug connection to the cell. Check the 'in-air' reading again.
14. Replace and recalibrate as required.

[Calibration at altitude](#) is covered on page 50.

Oxygen sensor tests

If the cells become affected by moisture or are nearing the end of their life they may read incorrectly and give the wrong readings. Items to look for when a cell is suspect:

1. When flushing with oxygen, look for a cell reacting slowly. This may have moisture on the face. Remove the cell and dry it gently by applying tissue paper to the face. Do not apply pressure to the face.
2. Periodically check the cells read greater than 7mv in air. If a cell appears to go out of calibration quickly, flush the loop with oxygen. Calibrate the cells on the Primary and Backup displays. Leave the loop closed for one hour full of oxygen and then check the cells again on the Backup display without switching the main electronics on. They should all be within 0.1 PO₂. Now flush with air, leaving the electronics off. The PO₂ on the Backup should read between 0.23 and 0.19.

Calibrating the Backup Display

1. Ensure the battery is good.
2. When running the pre-dive sequence, once you have the [loop flushed with oxygen](#), monitor the PO2 on the Backup Display and decide if any of the three displays need adjusting.
3. Turn the large blank cap on the rear of the Backup Display corresponding to the un-calibrated cell. If you run out of range on the control, try screwing it right in and start again. **DO NOT SCREW THE CAP RIGHT OUT TO EXPOSE THE SEALING O RING AS THIS WILL FLOOD THE BACKUP DISPLAY.** If the backup will not calibrate then confirm the cell millivolt reading in air is above 7millivolt and start the calibration routine again.
4. With the loop still fully of oxygen, make sure the Backup Display oxygen reading is the same as the calibrated Primary Display readings.

Now continue with the on screen Pre-dive checks prior to diving, either by turning the unit off and on again or if you are calibrating in the middle of the pre-dive sequence the unit will automatically continue with the Pre-dive once calibrated.

5. If you completely undo the cap, clean and re-grease the waterproof cover O-ring and refit, **being careful not to cross-thread the cap.**

OUROBOROS

On screen Pre-dive checks

Turn on the unit by either touching both wet contacts on the electronics pod or doing a short press of any button. This will bring up the [Turn On screen](#).

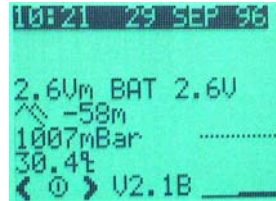

A long press of both buttons then takes the unit into the first of the Pre-dive check displays.

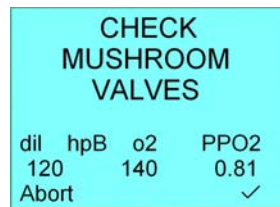

If you ABORT any of the checks, the ABORT will be stored in the dive log.

In extreme cases it may be required to ABORT a test and still continue diving. For this reason the rebreather employs a 'no lockout' policy but will record an ABORT procedure.

Simply follow the on screen prompts and complete the following tests.

In each case:

- Abort = short press of left button. Alarm will be recorded and displayed in [Sum - Summary screen](#)
- OK = tick short press of right button. Tick when task has been performed on rebreather by operator

These screens guide the diver through a series of [pre-dive checks](#) that provide a high confidence level that the rebreather systems and sub-systems are working and setup correctly. **If these checks are not performed, then an alarm check is recorded and advised in the summary screen.**

Failure to do Pre-dive checks increases the risk of INJURY or DEATH

- The checks can be aborted at any time using a short press of the left button. An alarm is recorded and advised in the summary screen.
- A short press of the right button will continue on to the next check





Predive Checks Table

Predive Check	RB Screen												
<p>1. CHECK MUSHROOM VALVES This can either be a visual check or blow into the mouthpiece while sealing the exhale hose and then suck while sealing the inhale hose. Check for leaking and any damage to the valves.</p> <div style="border: 1px solid black; padding: 5px; text-align: center; margin-top: 10px;"> <p><u>Always replace a suspect valve.</u></p> </div>	<div style="background-color: #e0ffff; padding: 10px; border: 1px solid black;"> <p style="text-align: center;">CHECK MUSHROOM VALVES</p> <table style="width: 100%; border-collapse: collapse;"> <tr> <td>dil</td> <td>hpB</td> <td>o2</td> <td>PPO2</td> </tr> <tr> <td>120</td> <td></td> <td>140</td> <td>0.81</td> </tr> <tr> <td>Abort</td> <td></td> <td></td> <td style="text-align: right;">✓</td> </tr> </table> </div>	dil	hpB	o2	PPO2	120		140	0.81	Abort			✓
dil	hpB	o2	PPO2										
120		140	0.81										
Abort			✓										
<p>2. DRAIN THEN TEST NEGATIVE With the cylinders connected but turned off. Evacuate the loop and perform a negative pressure test as per page 11.</p>	<div style="background-color: #e0ffff; padding: 10px; border: 1px solid black;"> <p style="text-align: center;">DRAIN THEN TEST NEGATIVE</p> <table style="width: 100%; border-collapse: collapse;"> <tr> <td>dil</td> <td>hpB</td> <td>o2</td> <td>PPO2</td> </tr> <tr> <td>120</td> <td></td> <td>140</td> <td>0.81</td> </tr> <tr> <td>Abort</td> <td></td> <td></td> <td style="text-align: right;">✓</td> </tr> </table> </div>	dil	hpB	o2	PPO2	120		140	0.81	Abort			✓
dil	hpB	o2	PPO2										
120		140	0.81										
Abort			✓										
<p>3. TURN ON O2 <u>Slowly</u> turn on the oxygen cylinder at least two full turns but not fully on.</p>	<div style="background-color: #e0ffff; padding: 10px; border: 1px solid black;"> <p style="text-align: center;">TURN ON O2</p> <table style="width: 100%; border-collapse: collapse;"> <tr> <td>dil</td> <td>hpB</td> <td>o2</td> <td>PPO2</td> </tr> <tr> <td>120</td> <td></td> <td>140</td> <td>0.81</td> </tr> <tr> <td>Abort</td> <td></td> <td></td> <td style="text-align: right;">✓</td> </tr> </table> </div>	dil	hpB	o2	PPO2	120		140	0.81	Abort			✓
dil	hpB	o2	PPO2										
120		140	0.81										
Abort			✓										
<p>4. Check O2 shutoff Check the O2 shutoff is open (pushed to the far right when wearing the unit).</p>	<div style="background-color: #e0ffff; padding: 10px; border: 1px solid black;"> <p style="text-align: center;">CHECK O2 SHUT OFF</p> <table style="width: 100%; border-collapse: collapse;"> <tr> <td>dil</td> <td>hpB</td> <td>o2</td> <td>PPO2</td> </tr> <tr> <td>120</td> <td></td> <td>140</td> <td>0.81</td> </tr> <tr> <td>Abort</td> <td></td> <td></td> <td style="text-align: right;">✓</td> </tr> </table> </div>	dil	hpB	o2	PPO2	120		140	0.81	Abort			✓
dil	hpB	o2	PPO2										
120		140	0.81										
Abort			✓										
<p>5. CHECK MANUAL O2 ADD Push the manual gas bypass valve and listen for gas entering the rebreather.</p>	<div style="background-color: #e0ffff; padding: 10px; border: 1px solid black;"> <p style="text-align: center;">CHECK MANUAL O2 ADD</p> <table style="width: 100%; border-collapse: collapse;"> <tr> <td>dil</td> <td>hpB</td> <td>o2</td> <td>PPO2</td> </tr> <tr> <td>120</td> <td></td> <td>140</td> <td>0.81</td> </tr> <tr> <td>Abort</td> <td></td> <td></td> <td style="text-align: right;">✓</td> </tr> </table> </div>	dil	hpB	o2	PPO2	120		140	0.81	Abort			✓
dil	hpB	o2	PPO2										
120		140	0.81										
Abort			✓										
<p>6. FLUSH O2 3 TIMES Run a calibration routine (page 20).</p>	<div style="background-color: #e0ffff; padding: 10px; border: 1px solid black;"> <p style="text-align: center;">FLUSH O2 3 TIMES</p> <table style="width: 100%; border-collapse: collapse;"> <tr> <td>dil</td> <td>hpB</td> <td>o2</td> <td>PPO2</td> </tr> <tr> <td>120</td> <td></td> <td>140</td> <td>0.81</td> </tr> <tr> <td>Abort</td> <td></td> <td></td> <td style="text-align: right;">✓</td> </tr> </table> </div>	dil	hpB	o2	PPO2	120		140	0.81	Abort			✓
dil	hpB	o2	PPO2										
120		140	0.81										
Abort			✓										

OUROBOROS

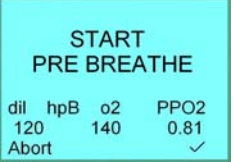
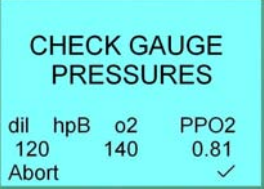
Pre-dive Check	RB Screen												
<p>7. CHECK O2 PO2 BACKUP AND PRIMARY Ensure the PO2 on both displays is within 0.05 bar of the PO2 of oxygen at the current ambient pressure.</p>	<p>CHECK O2 PO2 SECONDARY AND PRIMARY</p> <table border="1"> <tr> <td>dil</td> <td>hpB</td> <td>o2</td> <td>PPO2</td> </tr> <tr> <td>120</td> <td></td> <td>140</td> <td>0.81</td> </tr> <tr> <td>Abort</td> <td></td> <td></td> <td>✓</td> </tr> </table>	dil	hpB	o2	PPO2	120		140	0.81	Abort			✓
dil	hpB	o2	PPO2										
120		140	0.81										
Abort			✓										
<p>8. TURN ON DILUENT Turn the diluent cylinder valve fully on.</p>	<p>TURN ON DILUENT</p> <table border="1"> <tr> <td>dil</td> <td>hpB</td> <td>o2</td> <td>PPO2</td> </tr> <tr> <td>120</td> <td></td> <td>140</td> <td>0.81</td> </tr> <tr> <td>Abort</td> <td></td> <td></td> <td>✓</td> </tr> </table>	dil	hpB	o2	PPO2	120		140	0.81	Abort			✓
dil	hpB	o2	PPO2										
120		140	0.81										
Abort			✓										
<p>9. CHECK MANUAL DILUENT ADD Push the manual gas bypass valve and listen for gas entering the rebreather.</p>	<p>CHECK MANUAL DILUENT ADD</p> <table border="1"> <tr> <td>dil</td> <td>hpB</td> <td>o2</td> <td>PPO2</td> </tr> <tr> <td>120</td> <td></td> <td>140</td> <td>0.81</td> </tr> <tr> <td>Abort</td> <td></td> <td></td> <td>✓</td> </tr> </table>	dil	hpB	o2	PPO2	120		140	0.81	Abort			✓
dil	hpB	o2	PPO2										
120		140	0.81										
Abort			✓										
<p>10. CHECK ADV INJECT Evacuate the loop once and listen for the ADV triggering. If it does not trigger check the ADV shutoff valve. To open the valve push it to the divers left.</p>	<p>CHECK ADV INJECT</p> <table border="1"> <tr> <td>dil</td> <td>hpB</td> <td>o2</td> <td>PPO2</td> </tr> <tr> <td>120</td> <td></td> <td>140</td> <td>0.81</td> </tr> <tr> <td>Abort</td> <td></td> <td></td> <td>✓</td> </tr> </table>	dil	hpB	o2	PPO2	120		140	0.81	Abort			✓
dil	hpB	o2	PPO2										
120		140	0.81										
Abort			✓										
<p>11. FLUSH WITH DILUENT Manually add diluent.</p>	<p>FLUSH WITH DILUENT</p> <table border="1"> <tr> <td>dil</td> <td>hpB</td> <td>o2</td> <td>PPO2</td> </tr> <tr> <td>120</td> <td></td> <td>140</td> <td>0.81</td> </tr> <tr> <td>Abort</td> <td></td> <td></td> <td>✓</td> </tr> </table>	dil	hpB	o2	PPO2	120		140	0.81	Abort			✓
dil	hpB	o2	PPO2										
120		140	0.81										
Abort			✓										
<p>12. TEST DIL PO2 BACKUP AND PRIMARY Check the PO2 level falls on both displays.</p>	<p>TEST DIL PO2 SECONDARY AND PRIMARY</p> <table border="1"> <tr> <td>dil</td> <td>hpB</td> <td>o2</td> <td>PPO2</td> </tr> <tr> <td>120</td> <td></td> <td>140</td> <td>0.81</td> </tr> <tr> <td>Abort</td> <td></td> <td></td> <td>✓</td> </tr> </table>	dil	hpB	o2	PPO2	120		140	0.81	Abort			✓
dil	hpB	o2	PPO2										
120		140	0.81										
Abort			✓										
<p>13. CHECK RUBBER MOUTHPIECE Inspect the rubber mouthpiece for leaks. <u>If this is faulty, water will enter the breathing loop.</u></p>	<p>CHECK RUBBER MOUTHPIECE</p> <table border="1"> <tr> <td>dil</td> <td>hpB</td> <td>o2</td> <td>PPO2</td> </tr> <tr> <td>120</td> <td></td> <td>140</td> <td>0.81</td> </tr> <tr> <td>Abort</td> <td></td> <td></td> <td>✓</td> </tr> </table>	dil	hpB	o2	PPO2	120		140	0.81	Abort			✓
dil	hpB	o2	PPO2										
120		140	0.81										
Abort			✓										

OUROBOROS

Pre-dive Check	RB Screen
<p>14. START PRE BREATHE</p> <div style="border: 1px solid black; padding: 5px; margin: 10px 0;"> <p>This is the most important test, shortening the test may endanger life.</p> </div> <p>While monitoring the PO₂, breathe the unit for 5 minutes to ensure no CO₂ breakthrough.</p>	
<p>15. CHECK GAUGE PRESSURES</p> <p>Ensure you have enough gas, including bailout, for the dive.</p>	
<p>16. ABSORBENT STACK TIME MINUTES USED</p> <p>Confirm you have enough remaining absorbent time for the dive or reset the stack to zero.</p>	
<p>17. CONFIRM DIVE PPO₂ SET POINT</p> <p>Confirm the setpoint is correct for the dive. It is best to start the dive on a low setpoint and then switch it to a higher one at depth.</p>	
<p>18. CONFIRM DILUENT</p> <p>Confirm you have the right dive gases selected. <u>Do not turn any bailout gases on in the gas list until they are needed.</u></p>	
<p>19. CHECK BAILOUT AND INFLATION</p> <p>Test the bailout regulator(s), suit and wing inflation and confirm gauge pressures.</p>	

OUROBOROS

Pre-dive Check	RB Screen
<p>20. /WARNING/ PRE-DIVE TEST ABORTED Failure to do PRE-DIVE checks increases the risk of INJURY or DEATH This screen only appears if one of the pre-dive operations has been aborted</p>	

Having completed the pre-dive checks and (if required) [calibrate](#) (page 20) the unit, it is ready to dive.

If you have set the unit up at home and have transported it to the dive site you must, as a minimum, do a negative loop test and a calibration confirmation (flush the loop with oxygen 3 times) as well as the remaining on screen Pre-dive checks, **before** entering the water

Turn on rules

As discussed the unit will turn on:

- when wet
- with a switch on the Primary display
- when it has reached approximately 1.6 bar as an absolute pressure

In the first two instances the first screen shown will be the 'Pre-dive check' screen. With a pressure turn on it will go straight into the [Main Dive Screen](#) (page 38).

If you enter the water and a problem occurs the first indication will be an alarm on the Heads Up Display (HUD). This will prompt you to look at the [SUM](#) screen on the Primary display which will define the problem.

The [alarm](#) conditions table for the HUD is found on page 81.

Diving Skills

The primary diving skills required to use any rebreather will be covered in your chosen agencies training program and will not be reviewed here. However, there are certain unit-specific skills which must be covered during your training course. These are detailed below.

Leak testing

See notes on [Finding leaks](#)

Calibration

See notes on [page 20](#)

Harness Adjustment

See notes on [page 13](#)

Buoyancy Control

Initially, in shallow confined water you will be required to maintain a hovering simulated decompression stop. You will then practice short ascent/descents initially in manual po2 and diluent addition mode and then in fully automatic mode. Ascent/descents will become more progressive as the course continues.

Open circuit bailout

On every dive you will perform an open circuit bailout upon arriving at the bottom. On some dives you may be required to do addition bailouts possibly back to the surface as defined by your instructor.

Manual flight

The majority of the dives on your training course will be using the unit in manual mode. That is to say with the electronics being set at a safe minimum PO2 so as to support life and minimize the risk of decompression but with the user directly controlling the oxygen level and decompression requirements.

For this you will be taught to use the manual gas addition systems and calibrate and use the Backup oxygen display as well as carrying and using backup time/depth instrumentation and decompression tables.

In this mode the oxygen controller will not be disabled but will be set just below the required PO2 level, the diver manually maintaining the required level. Any decompression requirements/tables will assume the automatically controlled level is being used.

The same manual control will apply to the ADV which will be disabled and the counter-lung volume adjusted manually using the gas bypass system.

OUROBOROS

Oxygen solenoid and ADV failure modes

In these failure scenarios you will learn to use the manual isolation valves, to set and re-set them. You will learn how to return the loop gas content to satisfactory breathable ratios by manually injecting oxygen and diluent and adding gas from external sources including an open circuit regulator.

In certain circumstances you will be trained to temporarily come off the breathing loop. Upon return you must review the loop gas content before breathing again.

Upon returning to the rebreather you must review the loop gas content (PO₂) before breathing again.

Oxygen/diluent flow rate demonstrations

The purpose of this drill is to simulate how much gas is left in the lines after a cylinder valve shutdown and how much affect this has on the PO₂ in the loop.

Only perform this skill in the presence of an Instructor

In a maximum of depth of **4 meters of water**, and with a stable PO₂ of 1.0, shut off the oxygen cylinder. Now use the manual bypass to add oxygen while breathing normally from the loop. You may need to vent to compensate for buoyancy.

Monitor the PO₂.

Shut off the diluent cylinder and breathe in and out through the nose. Repeat this until the counterlungs start to collapse, add a little gas to be comfortable.

Note the PO₂. Now turn on the diluent **and the oxygen** cylinder.

With increased depths the changes will be more dramatic but this test shows the limited amount of gas remaining in the gas lines after a shutdown and hence the limited risk of gas loss and PO₂ 'spiking' that can occur.

Dependent on the diluent used, the drop in PO₂ may be more rapid.

Do not use diluents for this test which generate a PO₂ of less than 0.21 at the test depth.

Diluent flushes

To do a diluent flush you can either use the ADV by exhaling through the nose until it triggers or by using the manual bypass. If you are trying to flush a high PO₂ it is best to go off the loop and onto open circuit to perform the flush using the manual bypass while compensating for buoyancy shifts.

If the PO₂ does not fall quickly enough you may have to isolate the oxygen circuit temporarily to correct the problem.

Flood Recovery

Condensate will naturally collect in the exhale hose on the diver's right and the exhale counter-lung. This will be signified by a 'gurgling' noise.

Moving water into the exhale counter-lung allows you to purge the water through the over pressure valve.

To move water into the counter-lung: Close the mouthpiece, put the hoses above your head and shake the hose, squeezing the exhale hose like squeezing an accordion will move water down the hose quickly.

Either now slightly over pressurize the loop until it vents while in an upright position or wait until you ascend and the unit naturally over pressurises.

If water continues to enter the loop, attempt to locate the leak and cure it. **A common leak point might be a mouthpiece which is not fully open or closed.**

If water is in the inhale hose, again close the mouthpiece and move the water across to the inhale hose and evacuate as before.

Bailout and ascents

Open circuit bailouts occur if a loop is unbreathable or flooded. In the unbreathable scenario the loop will need to vent during the ascent and the injection of gas will need to be inhibited to avoid buoyancy problems. This can be done by either closing the cylinder valves or the O₂ and diluent shutoff valves.

With a flooded loop the diver must carry sufficient additional buoyancy to overcome approximately 5kg of buoyancy loss. The gas injection should again be isolated.

Ascents must be practiced on the training course while on open circuit and with a loop full of gas.

Oxygen sensor isolation

The Ouroboros has the ability to automatically deselect faulty oxygen sensors. However there may be instances when you wish to override the computers decision. This can be done by manually turning off sensors in the [O₂ screen](#) on page 48.

Before deselecting a sensor, the PO₂ should be confirmed by doing a diluent flush (with oxygen injection temporarily disabled). The PO₂ of your selected diluent at the current depth is displayed on the dive [Decompression Screen Summary](#) on page 56.

OUROBOROS

Off-board gas selection

Each of the oxygen and diluent gas blocks has the facility to plug in additional gas to a valve on its base.

If the gas plugged in is the same as the on board gas then the on-board cylinder valve can be left open. If the on-board and off-board gases are different then the on-board gas cylinder valve must be turned off.

Now breathe the loop down three times, exhaling through your nose to purge the loop of the previously selected diluent.

Make sure that after plugging in the new gas and turning off the in-board cylinder, you change to the new diluent on the [dive screen](#).

When the off-board valves are disconnected you should replace the protection caps to stop dirt and sand entering the valve.

Failure to select the correct breathing gas on the computer may result in decompression sickness, injury and even death.
--

Electronic bailouts

With the Ouroboros it is possible to do an [open circuit bailout](#) and switch the electronics to open circuit mode to track the new open circuit decompression.

Alternatively, if the readings from the sensors are good (as confirmed on the Backup display) but are being fed to the Main electronics incorrectly then you have the option to [turn off the PO2 tracking](#) algorithm and have the unit follow an internal setpoint (which you can select on the Primary display) while you maintain the PO2 manually and monitor it on the Backup display.

Ouroboros Rebreather Primary and Heads-up Display Menu System

Introduction

The Primary display screen system operates in-conjunction with two magnetic reed switches operated from the front of the Primary display unit. These switches are referred to as the left and right switches when viewing the screen.

There are six types of Primary display switch press combinations:

1. Left switch – short press
2. Right switch – short press
3. Both switches together – short press
4. Left switch – long press
5. Right switch – long press
6. Both switches together – long press

These are utilised to access the full range of menu functions on the Primary display.

The Heads-up display (HUD) works in conjunction with the Primary display and uses four LED lights to warn the diver of the changing status of the unit. The different colour LEDs correspond to different groups of Alarm types. As a basic rule, a Flashing LED is a warning. A static or off LED is an OK condition. A fast flash indicates a different Alarm state to a slow flash. As there are many combinations, the diver should use the HUD in combination with the primary display. When the primary display is in the [Main Dive Screen](#), the top right corner of the display will give an indication of the highest priority Alarm, which will correspond to a flashing LED on the HUD. In the case of more than one Alarm state, the diver should look at the [Sum - Summary screen](#) to get more information. From the [Sum - Summary screen](#), the diver can also deactivate the vibration alarm that comes on when major alarms are detected.

The table below gives the Alarm types indicated by the HUD.

OUROBOROS

The HUD light sequence is:

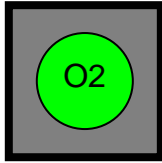
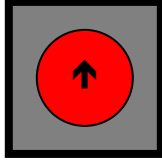
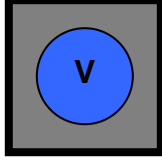
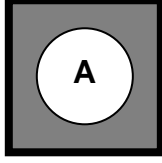
Warning	HUD LED operations		
PO2			
PO2 within 0.10 bar of setpoint	Green LED on solid		
Very Low PO2	Green LED slow flash		
Low PO2	Green LED slow flash		
High PO2	Green LED Fast flash		
Decompression Ceiling			
At decompression stop within -0/ +1m	Red LED on solid		
Deco ceiling violated stop	Red LED fast flash		
Deco stops required	Red LED slow flash		
Solenoid Valve			
Valve electrically activated OK	Blue LED single short flash		
Valve electrical activation fault	Blue LED fast flash		
If valve mechanically stuck, valve activation may show ok, but valve still stuck open or closed	HP rate and PO2 alarms will trigger		
General Alarms			
HP alarms			
Low HP content	White LED slow flash		
High HP usage rate	White LED Fast flash		
Low HP usage rate	White LED Fast flash		
Ascent Rate			
Fast ascent rate	White LED Fast flash		
Batteries			
Low Main Battery	White LED slow flash		
Low Valve battery	White LED slow flash		
Pre-dive check			
PRE-DIVE aborted	White LED slow flash		
PO2 cells			
Low mV reading	White LED slow flash		
Due to many alarm conditions using this White LED, the Primary display (SUM screen) should be checked to determine which fault is activating the alarm			

Primary Display. Left and right switch presses

On the screens, the left and right switch press functions are shown on the left or right of the screen appropriately. The difference between a long or short press depends on the screen.

From the [Main Dry Screen](#) and [Main Dive Screen](#) a long press of either button is required to go to a new screen. A short press will toggle round the menu options.

On screens where a number can be incremented, a short press will only increment or decrement by the minimum step, usually one. A long press will generally increment or decrement 10 times the short press value.

In other screens, generally a long or short press of the left or right buttons performs the same function.

Pressing both switches together

The function for a short press of both is given inside thin brackets < >.

The function for a long press of both buttons is given inside a thicker bracket <>.

OUROBOROS

Screen list

Below is the list of the main Primary display screens specific to Ouroboros operation. Other screens are covered in the VR3 operations manual supplied with the unit.

[On screen Pre-dive checks](#) page 22.

[Main Dry screen](#) page 35.

[Main Dry Screen-Saver](#) page 37.

[Main Dive screen](#) page 38.

[Main Dive Screen-Saver](#) page 43.

[Turn on screen](#) page 44.

[Open/Closed PO2 screen](#) page 45.

[Gas select screen](#) page 46.

[Gas Adjust screen](#) page 47.

[Dvo screen](#) page 52.

[HP/Stack screen](#) page 55.

[o2 sensor screen](#) page 48.

[o2 sensor Calibrate screen](#) page 49.

[Sum - Summary screen](#) page 57.

[Re-programming system](#) page 87.

Main Dry Screen

This is the Home screen when the unit is not being dived. From here, through the use of other sub-menus, the rebreather can be setup to the required condition prior to diving.

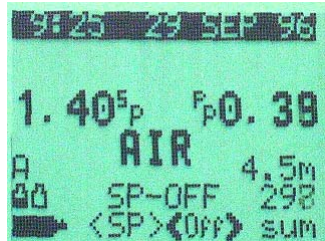

This screen is active:

- After completing the Pre-dive turn on procedure
- After exiting to Home from other screens when the rebreather is not in dive mode

If there are Alarms in the System the user is prompted not to dive, and to check the alarms in the SUM screen, accessed as shown in item 7 below.



From this screen the operator can:

1. **Turn the rebreather off – Long press both buttons**
A countdown from 4 seconds is activated to turn off after a long press of both buttons. This can be aborted by pressing another switch before the countdown has completed. The seconds to turn off can be seen in the bottom right corner, above the right menu icon.
2. **Turn setpoint ON/OFF – Short press both buttons toggles the setpoint ON/OFF**
This selects whether the rebreather is trying to reach the dive setpoint, or the safe non-dive setpoint of 0.4bar. When the setpoint is off, the rebreather still maintains a breathable gas mixture of 0.4bar, assuming the cylinders are turned on by the diver. When the setpoint is turned on, the rebreather tries to maintain the diving setpoint. Depending what this is set to, this may not be achievable, and the unit will waste O₂ and battery power in trying to achieve it -

OUROBOROS

hence the ability to turn the setpoint off. **When the unit is dived the setpoint is automatically turned on.**

Using a short press of the left or right buttons, the menu options available on the left and right buttons can be rotated through. When the desired option is shown on the left or right corner menu icon, then the option is selected by a long press of the appropriate button. The options that can be found on each button are:

Left button:

3. **[Open/Closed/PO2 setup screens](#) - Long press of left button when Gas cylinder is displayed**
This will give access to the Open/Closed and PO2 select screen.
4. **[HP and Stack status screen](#) - Long press of left button when HP gauge is displayed**
This will give access to the HP content and Stack status screen.
5. **[Dvo screen](#) - Long press of left button when Dvo is displayed**
This will give access to the Dvo screen, from which warning and miscellaneous operating modes are selected, eg light mode.

Right Button:

6. **[o2 sensor screen](#) - Long press of right button when O2 is displayed**
This will give access to the [o2 sensor screen](#), from where individual cell levels and status can be displayed and controlled.
7. **[sum screen](#) - Long press of right button when sum is displayed**
This will give access to the summary of alarms and external readings. The first screen entered shows first page of current alarm conditions.
8. **[Options screen](#) - Long press of right button when options icon is displayed**
This gives access to another set of sub menus that are only available when not diving.

Main Dry Screen-Saver

The screen below is activated from the [Main Dry Screen](#) if a switch button has not been activated for 30 seconds. It is also activated if the unit is in any of the other post pre-dive surface screens, and a button has not been activated for 3 minutes.



This display shows:

- alarm conditions in top
- current average PO2 in bottom left
- individual cell readings and usage in bottom right corner. Usage codes display whether the cell is being used by the computer average PO2:
 - Y = used
 - D = disabled by user
 - N = automatically taken out of average by computer system.

Once the screen is active, the [Main Dry Screen](#) can be restored by pressing any button.

OUROBOROS

Main Dive Screen

This is the main Home screen when the rebreather is being dived. From here, through the use of other sub-menus, the rebreather can be further adjusted for eventualities occurring while diving, and for displaying other parameters useful to the diver when diving, eg decompression stops. When in screens while diving, the current depth, current dive time and current average PPO2 are displayed in the top of the screen. The exceptions to this are:

- The Main dive screen, as this has the PPO2 in the display already.
- The [O2 sensor Screen](#), as this screen has all PPO2 information.
- The [Sum - Summary screen](#).

Below is the main dive screen showing the current tissue-loading graph in the top right corner.

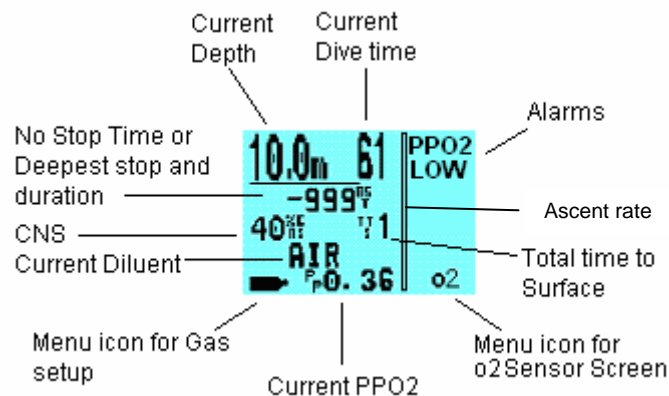
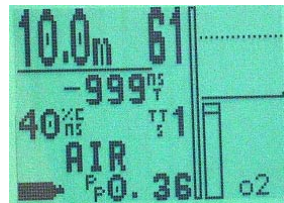

If there are fault or alarm conditions detected by the rebreather control system, then the top right corner will show the faults.

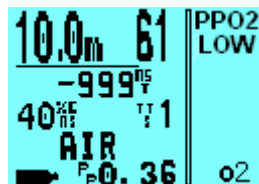

If more than one fault is detected, the highest priority one **only** will be shown. Check the [Sum - Summary screen](#) for the full Fault and RB status.

Check the [Sum - Summary screen](#) for the full Fault and RB status.





The table below lists the alarm conditions and suggested action.

Dive Screen Alarm Conditions

Alarm	Description	Action
RB OFF	Rebreather has been manually turned off	Use rebreather manually, or use bailout gas
PPO2 LOW	Average PPO2 reading from cells less than 0.10Bar of setpoint, but greater than 0.4Bar	Manually add o2. Check o2 addition valve. Check O2 cells reading correctly. Consider using bailout.
PPO2 HIGH	Average PPO2 reading from cells greater than 0.10Bar above setpoint, but less than 2.0Bar	Manually add diluent. Check o2 addition valve. Check O2 cells reading correctly. Consider using bailout.
PPO2 VLOW	Average PPO2 reading from cells less than 0.4Bar.	Manually add o2. Check o2 addition valve. Check O2 cells reading correctly. Use bailout.
PPO2 VHIGH	Average PPO2 reading from cells greater than 2.0Bar	Manually add diluent. Check o2 addition valve. Check O2 cells reading correctly. Use bailout.
VALVE FAIL	System has not detected valve fire feedback, or has detected failure in valve firing system.	Check battery levels. Check PPO2 levels. Consider turning RB off, and manually adding o2. Consider using bailout.
STACK LOW	Stack time remaining for CO2 absorbent is running low.	Do not start new dive. Finish current dive as quickly and safely as possible. Consider using bailout.
BAT LOW	Battery level low.	Change ALL batteries in rebreather.
Hpdil LOW	High pressure diluent cylinder gas below reserve level of 50Bar	Consider using bailout. Switch to reserve diluent on off board manifold if available.
O2Cell ERROR	One or more cells being excluded from averaging	Check PO2 individual cell readings. Check Backup display

OUROBOROS

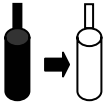
Dive Screen Alarm Conditions - continued

Alarm icon	Description	Action
Down Arrow with seconds counter 	Violation of decompression ceiling – remaining seconds displayed to get back to ceiling	Descend to decompression ceiling
Up Arrow 	Too deep for current depth, with no alternative active gas.	Ascend to MOD of deepest gas
Open hand 	Indicates ascending too quickly	Stop at current depth to slow down
Gas cylinders 	Gas being used is not as per the MOD for the active gas list for the current depth	Change gas to advised gas based on MOD, unless not appropriate – ie still in descent part of dive, not decompression
Grid – Use Table 	Decompression ceiling has been violated for longer than 1 minute.	Backup tables should now be used for decompression
HP Low	High pressure cylinder sensors indicate low high pressure reading – less than reserve level	Check cylinder pressure and take appropriate action – bailout/conserves gas/ascend
Cylinder – Air Break 	CNS reached alarm level. Repeated every 30 minutes for 5 minutes.	Use a low po2 gas, eg air for 5 minutes to reduce CNS toxicity problems

There are also features in the dive screen that can assist the diver during the dive:

Dive Screen Display Features

Display Feature	Description	Action
Ascent rate indicator	Center of indicator equates to an ascent rate of 10 meters per minute	Adjust ascent rate to ensure optimum speed.
Decompression ceiling	Diver icon moves nearer to top right corner as diver approaches decompression ceiling. Feature is enabled when within 3 meters of ceiling	Allows diver to optimise decompression depth
Tissue graph	Display of 16 tissue compartments with reference level to tolerated maximum at surface	Visual feedback to diver of current tissue state

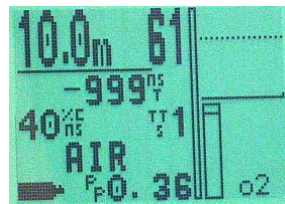

This screen is active:

- When the unit first enters dive mode – i.e. after 1.5meters dive depth has been reached if the unit is already on, or 1.6Bar absolute pressure if the unit is not turned on.
- After choosing a dry dive mode, used when performing dry chamber dives – not available in sports version
- After exiting to Home from other screens when the rebreather is in dive modes

From this screen the operator can:

1. **Make a mark in dive profile log– Long press both buttons**
This will cause a log marker in the dive profile that can then be downloaded to a PC for analysis after the dive. Simply a reference point for the diver, should it be useful.
2. **Toggle top right hand sub-display– Short press both buttons toggles the top right sub display**
This selects the top right sub-display between:
 - a. No sub-display
 - b. Dive timer
 - c. Tissue loading graph

OUROBOROS

Using a short press of the left or right buttons, the menu options available on the left and right buttons can be rotated through. When the desired option is shown on the left or right corner menu icon, then the option is selected by a long press of the appropriate button. The options that can be found on each button are:

Left button:

3. **Open/Closed/PO2 setup screens** - Long press of left button when Gas cylinder is displayed
This will give access to the Open/Closed and PO2 select screen.
4. **HP and Stack status screen** - Long press of left button when HP gauge is displayed
This will give access to the HP content and Stack status screen.
5. **Dvo screen** - Long press of left button when Dvo is displayed
This will give access to the Dvo screen, from which warning and miscellaneous operating modes are selected, eg light mode.

Right Button:

6. **o2 sensor screen** - Long press of right button when O2 is displayed
This will give access to the o2 sensor screen, from where individual cell levels and status can be displayed and controlled.
7. **sum screen** - Long press of right button when sum is displayed
This will give access to the summary of alarms and external readings. The first screen entered shows first page of current alarm conditions.
8. **Decompression Screen Summary** - Long press of right button when Deco ↑ options icon is displayed
This gives access to a full list of pages of decompression stops. At the end of the list, there is a dive summary screen displaying Max depth, Temperature, OTU and PO2 max.

Main Dive Screen-Saver

The screen below is activated from the [Main Dive Screen](#) if a switch button has not been activated for 30 seconds.

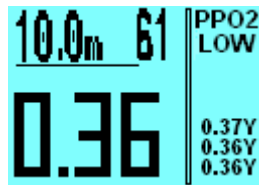

This display shows:

- current depth in top left corner
- current dive duration in top middle
- alarm conditions in top right
- current average PO2 in bottom left
- individual cell readings and usage in bottom right corner. Usage codes display whether the cell is being used by the computer average PO2:
 - Y = used
 - D = disabled by user
 - N = automatically taken out of average by computer system.

Once the screen is active, the [Main Dive Screen](#) can be restored by pressing any button.

OUROBOROS

Turn On screen

This screen is displayed when a button is pressed when the unit is off. The screen will be active for approx 30 seconds after a button press. To start the rebreather up, a Long press of both buttons is required from this screen.

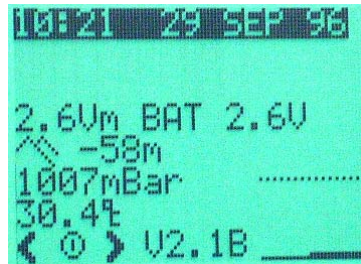

From the Turn on screen, the operator can:

1. **Turn the rebreather on – Long press of both buttons.**
This takes the unit into the first of the Pre-dive screens. For safe operation, the unit must always be turned on and system checks performed before breathing from the rebreather. The PRE-DIVE screens assist the diver in performing these checks.

2. **Toggle the bottom right sub-display– short press of both buttons.**
This selects the sub-display between:
 - d. No sub-display
 - e. Clock
 - f. Tissue loading graph

Other information displayed in this screen:

- Date and Time – Top row
- User details – user programmable name and contact details
- Approximate altitude compared to 1000mBar = 0m
- Approximate Atmospheric pressure – used to adjust calibration gas PO2 level. See [Atmospheric Adjustment](#)
- Temperature
- Battery levels
- Version number of software

Open/Closed and PO2 select screen

This is the first level of breathing mode and PO2 level adjusting. It is designed to be simple to use for quickly adjusting parameters when on the surface or diving. The main use is for adjusting the PO2 setpoint of the rebreather.

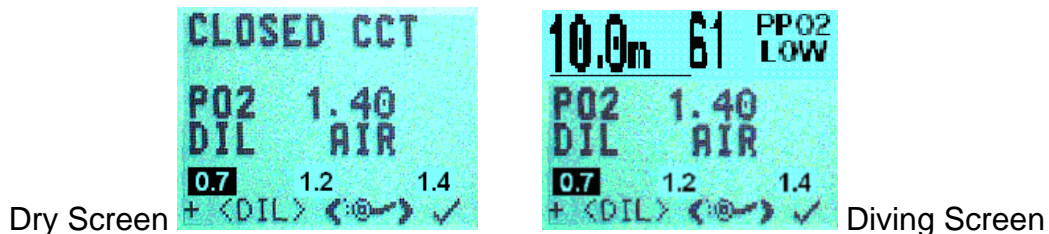

From the Open/Closed PO2 select screen, the operator can choose:

1. **PO2 Increment – Short press of left button**
This increments the PO2 setpoint value by 0.05Bar. The maximum value is 2.00 Bar. After this, an increment will cause the setpoint to go back to the lowest value of 0.40Bar.
2. **PO2 Preset – Long press of left button**
This selects the highlighted preset PO2 setpoint value from the second line from the bottom of the screen. Thus it becomes quick to toggle between different setpoints, as maybe used for travel and decompression.
3. **Diluent select – Short press of both buttons**
This enters the [Gas Select screen](#), so that the user can change the current diluent being used in the breathing gas.
4. **Open/Closed circuit select – Long press of both buttons**
This allows the operator to enter the open circuit system and turn the rebreather control off. **Caution should be used when entering Open circuit mode, as all PO2 control will be disabled.**
5. **Confirm settings – Short press of right button**
This allows the operator to exit the screen and confirm the settings are correct

OUROBOROS

Gas Select Screen

This screen allows the operator to select the diluent/open circuit gas from the current list of enabled gases. Note, that any enabled gases will be used in the decompression look ahead based on the mod of each gas. Therefore it is important to plan the diluent gases enabled in-line with those that will actually be used during the dive. This will make sure the decompression look ahead is as accurate as possible. **Do not enable bailout gases.**

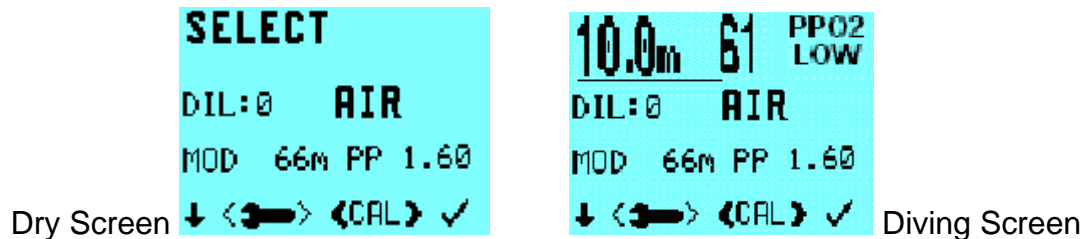

Gases can be enabled, disabled and adjusted from the [Gas Adjust Screen](#).

From the Gas select screen, the operator can:

- 1. Scroll down list of active gases – Short press of left button**
This allows the operator to enter scroll down the list of active gases
- 2. Enter Gas Adjust screen – Short press of both buttons**
This allows the operator to enter scroll down the list of active gases
- 3. Exit – Short press of right button**
This allows the operator to exit and confirm the gas setup
- 4. Choose CAL gas SURFACE ONLY – Long press of both buttons**
This allows the operator to select the [calibration gas](#) for the O2 sensors. **This is only used and available on the surface.**

Gas Adjust Screen

This screen allows the operator to adjust the diluent and open circuit gases, and enable or disable them for the dive.

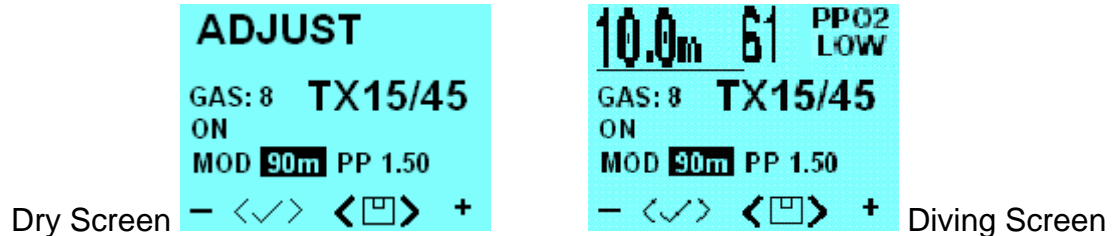

Note, that any enabled gases will be used in the decompression look ahead based on the MOD (maximum operating depth) of each gas. Therefore it is important to plan the diluent/open circuit gases enabled in-line with those that will actually be used during the dive. This will make sure the decompression look ahead is as accurate as possible.

Enabled Diluent and open circuit gases

The diluent gases and open circuit gases share the same gas list. Therefore the diluent gases become the open circuit bailout gases in open circuit mode. Any gases enabled for diluent will be enabled as open circuit. This also applies vice versa, that is any enabled open circuit gases will be enabled as diluent for closed circuit mode. Therefore always ensure these gases are properly configured for the dive mode currently in use.

OUROBOROS

O2 sensor Screen

This screen allows the operator to view individual cell levels and status. The cells can also be disabled in event of failure. When on the surface, the O2 sensors can be calibrated.

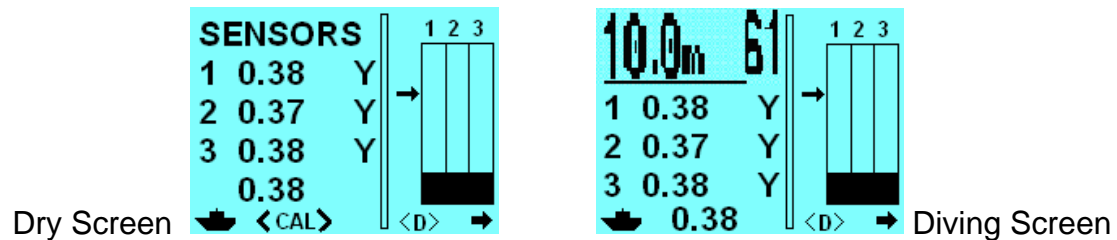

From the O2 sensor screen, the operator can:

- 1. Enable/Disable sensor – Short press of both buttons**
This allows the operator to toggle the sensor between a enabled (Y) and Disabled (D) state. A disabled sensor will not be used in the sensor averaging. An enabled sensor will be used as long as its reading is in close proximity to the other enabled cells. The rebreather will not use N cells that are out of range. It will also not use cells that have a dissimilar reading to the other cells. See [o2 sensor polling](#) page 49 for more details on this automatic disabling and averaging.
- 2. Scroll down list – Short or long press of right button**
This allows the operator to enter scroll down the list of active gases
- 3. Enter CAL mode SURFACE ONLY – Long press of both buttons**
This allows the operator to enter the [o2 sensor calibrate screen](#). This is used to calibrate the po2 sensors and thus ensure that the rebreather is controlling as accurately as possible, and that the decompression calculations are using the appropriate po2 value.

O2 sensor Calibrate Screen

This screen allows the operator to calibrate the po2 sensors and thus ensure that the rebreather is controlling as accurately as possible, and that the decompression calculations are using the appropriate po2 value.

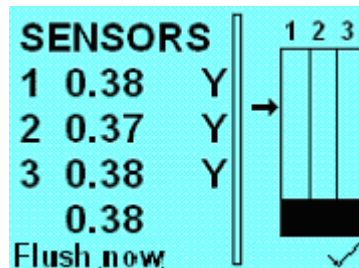

NOTE: ANY SENSORS THAT THE OPERATOR THINKS ARE NOT WORKING CORRECTLY SHOULD BE REPLACED BEFORE ENTERING THIS SCREEN FROM THE [O2 sensor Screen](#).

From the O2 sensor screen, the operator is prompted to perform [flushing of the breathing loop](#) with the Calibration Gas

When this has been done, a press of the right switch moves the operator to next screen. The operator is then prompted to Vent the breathing loop momentarily by opening the mouthpiece and **closing it** again to equalize the pressure in the loop.

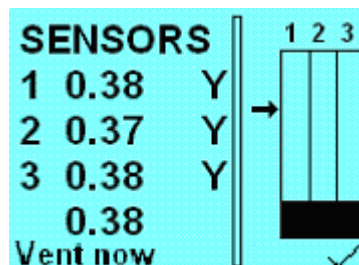

When this has been done, a press of the right switch moves the operator to next screen. The rebreather is then checking all the sensors for a stable reading. The rebreather will then automatically calibrate the sensors. Alternatively the user can use a short press of both switches to force the rebreather to calibrate. This is not advised, but in extreme cases can be used where the operator has no alternative but to use very unstable sensors.

OUROBOROS

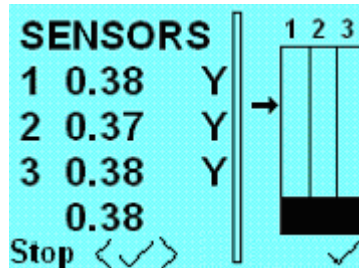

When the calibration is complete, the operator is then taken to the first of the [On screen Pre-dive checks](#). Now that the rebreather has an updated calibration, all pre-dive functionality checks should be done to ensure the calibration is correct.

Calibration Gas

The calibration gas is setup from the [Gas Adjust Screen](#). The calibration gas is the gas used in the rebreather O2 cylinder. This is normally 99% oxygen. However, should a slightly weaker O2 be used, then the CAL gas should be adjusted accordingly. Then the calibration of the O2 sensors will be compensated accordingly.

Atmospheric Adjustment

Atmospheric adjustment is carried out automatically, during the calibration, by multiplying the calibration gas O2 level by the current ambient pressure in Bar. This ensures the most appropriate PO2 is used by the rebreather.

Example: 98% O2 x 0.950 bar atmospheric = 0.931 Bar

1. Flush Now

A short press of the right button confirms that the breathing loop has been [properly flushed](#) with the O2 [Calibration Gas](#).

2. Vent Now

A short press of the right button confirms that the breathing loop has been vented at the mouthpiece to ensure there is not an overpressure in the breathing loop.

3. Calibrating..

After the 'vent now' operation is confirmed, the rebreather now monitors the active sensors, and performs the appropriate calibration calculations. This process can be stopped by a press of the left button. The process can also be manually confirmed by a short press of both buttons, in case the unit is taking an excessive time in getting a stable reading – eg water on the cells. However, normal practice would be to let the unit continue to calibrate automatically, to ensure the best accuracy.

O2 Sensor Polling

The rebreather has a method of automatically removing O2 sensor cells from the PO2 averaging. This is based on a set of rules. If the operator considers these are not appropriate for a particular type of cell failure, then any individual cell can be turned off manually. See the [O2 sensor Screen](#).

Rules:

1. If all cells have been disabled by the user, all will be turned back on.
2. If a single cell is below 0.15 bar or above 3.00bar, then it will be disabled.
3. If after item 2, all 3 cells are disabled for the same fault, then all cells will be re-enabled – this ensures that if the O2 is very high, or very low and all the cells agree, then the O2 is probably very high or low accordingly.
4. If all cells are enabled and have no faults, then each cell is checked to see how many other cells it is within 0.20bar of.
 - a. If all cells are within 0.20bar of each other, then all cells will be enabled.
 - b. If two cells are within 0.20bar of each other and one cell is not, then the cell that is not within 0.20bar of the others will be disabled.
 - c. If no cells are within 0.20bar of each other, then all cells will be kept enabled.
5. If all 3 cells are disabled with the same fault at this stage, then all will be re-enabled.
6. All enabled cells are then used in the PO2 averaging. Any cell disabled in these calculations will have a D shown against it in the [O2 sensor Screen](#).
7. Examples:
 - a. Cell 1 = 0.5bar, cell 2 = 0.60bar, cell 3 = 0.70bar. All cells used
 - b. Cell 1 = 0.3bar, cell 2 = 0.60bar, cell 3 = 0.70bar. Cells 2 and 3 only used
 - c. Cell 1 = 0.3bar, cell 2 = 0.60bar, cell 3 = 0.14bar. Cell 1 and 2 only used
 - d. Cell 1 = 0.3bar, cell 2 = 0.60bar, cell 3 = 0.90bar. All cells used as no obvious fault in any single cell

OUROBOROS

Dvo Screen

This screen enables Diving option modes of the re-breather to be adjusted while on the surface or diving.



- To move around the different modes, use a short press of both buttons
- To change a mode use the + or – buttons. That is a short or long left or right button press.
- To exit this screen use a long press of both buttons

Parameters to change are:

1. Light Mode: Lite
 - a. Off = Light is always off
 - b. Tm = Light is on for 10 seconds after button press
 - c. DTm = Light is off when not diving. Light is on for 10 seconds after button press when diving
 - d. On = Light is always on when unit is on, except when in PC interface link
 - e. Don = When not diving Light is on for 10 seconds after button press. When diving light is always on.
2. HUD brightness: HUD
 - a. Hi = Hud is high brightness
 - b. Lo = Hud is low brightness
3. XDeco: External po2 value used in decompression calculations
 - a. XDc = on: External po2 values from the 3 sensors used for decompression calculations
 - b. XDc = off: External po2 value not used for decompression calculations. Setpoint will be used for closed circuit dives. Gas mix details used for open circuit dives.
4. RBvalve: Valve on and valve off times in seconds
 - a. 1 8 : O2 inject valve on time = 1 second with wait time of 8 seconds.
 - b. ¼ 8 will be shown if backup battery being used. O2 inject valve on time = ¼ second with wait time of 8 seconds.
 - c. Inject time can be changed to OFF. This will turn off all rebreather valve firing and should only be used is manual oxygen addition is to be used by the diver. Off mode will be activated after confirming Rebreather Off when exciting screen. This mode is reset to a 1 second on interval if the unit is turned off then back on again.

Dvo Screen - Advanced

This version of the screen includes features which are not available on the recreational version of the unit.

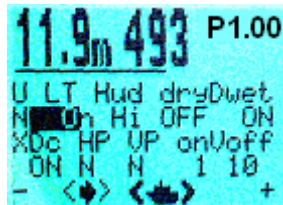

- To move around the different modes, use a short press of both buttons
- To change a mode use the + or – buttons. That is a short or long left or right button press.
- To exit this screen use a long press of both buttons

Parameters to change are:

1. Light Mode: LT
 - a. Off = Light is always off
 - b. Tm = Light is on for 10 seconds after button press
 - c. DTm = Light is off when not diving. Light is on for 10 seconds after button press when diving
 - d. On = Light is always on when unit is on, except when in PC interface link
 - e. Don = When not diving Light is on for 10 seconds after button press. When diving light is always on.
2. HUD brightness: HUD
 - a. Hi = Hud is high brightness
 - b. Lo = Hud is low brightness
3. dryDwet: Dive mode select
 - a. dry = on: Dive mode entered independently of depth. Used for dry chamber dives to keep unit on, or shallow dives
 - c. dry = off: Dive mode will be entered based on Wet mode
 - d. Wet = on: Dive mode will be entered when depth is greater than 1.5m as read on depth transducer
 - e. Wet = off: Dive mode will not be entered even if at depth. Used for chamber dives or when decompressing or transporting in bell
4. XDc: External po2 value used in decompression calculations
 - a. XDc = on: External po2 values from the 3 sensors used for decompression calculations
 - b. XDc = off: External po2 value not used for decompression calculations. Setpoint will be used for closed circuit dives. Gas mix details used for open circuit dives.

OUROBOROS

This should only be selected if the readings on the Primary display are obviously incorrect and the Backup display is correct. The Backup can then be used with manual control of the PO2. Decompression will be defined by the setpoint on the Primary display. **Solenoid firing will be disabled.**

5. HP: Choose if HP alarms are active
 - a. HP = Y: HP alarms are active
 - b. HP = N: HP alarms are not active

6. VP: Proportional valve control
 - a. VP = Y: Proportional valve control on. The wait time between valve injects will be reduced to 3 seconds when the po2 reading is more that 0.20bar away from setpoint. When within 0.1bar but just below setpoint, $\frac{1}{4}$ and $\frac{1}{2}$ second injects are used to achieve minimal overshoot of po2.
 - b. VP = N: Proportional valve control is off. The wait time between valve injects will remain as set in the Valve off time independently of difference of po2 from setpoint. O2 will not be injected if within 0.1bar of setpoint.

7. onVoff: Valve on and valve off times in seconds
 - a. on = 1 : O2 inject valve on time = 1 second
 - b. on = $\frac{1}{2}$: O2 inject valve on time = 0.5 second
 - c. on = $\frac{1}{4}$: O2 inject valve on time = 0.25 second
 - d. on = 2 : O2 inject valve on time = 2 seconds
 - e. off = 20 : valve off or wait time is settable to any time between 20 and 5 seconds
 - f. off = 5 : valve off or wait time is settable to any time between 20 and 5 seconds
 - g. If On is reduced from $\frac{1}{4}$ then the OFF option is selected. This will turn off all rebreather valve firing and should only be used is manual oxygen addition is to be used by the diver. Going from 2 seconds higher will go to $\frac{1}{4}$ second not OFF. Off mode will be activated after confirming Rebreather Off when exciting screen. This mode is reset to a 1 second on interval if the unit is turned off then back on again.

Off mode will be activated after confirming Rebreather Off when exciting screen. This mode is reset to a 1 second on interval if the unit is turned off then back on again.

8. U – Selects remote ultra-sonic link data transmission.
 - a. ON = Transmission on.
 - b. OFF = Transmission off.

OUROBOROS

HP / Stack screen

This screen displays the high-pressure contents of the Diluent and O2 cylinder.



The cylinder valve must be turned on for these readings to show the correct values.

If the units are set to m (meters) then the display will be in bar.

If the units are set to f (feet), then the display will be in PSI.

The Stack time used in minutes is displayed. This can be reset to zero using a short press of the right button when not diving.

A periodic check on the accuracy of the HP sensors should be carried out every 6 months. To do this, put a cylinder of known pressure into each of the cylinder high pressure connections. Check the HP readings against the expected value. If there is a discrepancy of greater than + or – 5 bar, contact the factory for recalibration services.

The screen is exited using the right button.

OUROBOROS

Decompression Screen Summary

This screen is displayed after the decompression stop list, by doing a further right button press. If there are no decompression stops, then it will be displayed immediately on entering the decompression list from the [Main Dive Screen](#).

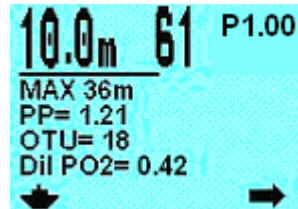

It displays:

- Maximum Depth
- Current PPO₂
- OTU (Oxygen Toxicity Units) for current dive
- Expected PO₂ after a diluent flush at your current depth of the breathing loop – this is used to test the Oxygen sensors and perform a 'diluent flush'.

Sum - Summary screen

This screen displays the summary of alarms and external readings. The first SUM screen shows currently active alarms. You can move between pages to view other system status.

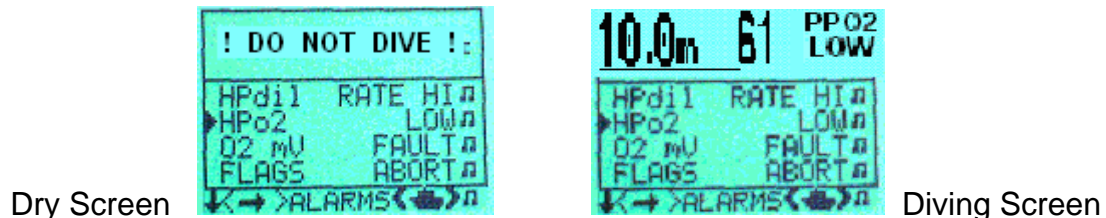

Alarms will occur on the Primary display and the HUD. The HUD will give a visual (flashing light) and a tactile/audible warning (it vibrates).

The HUD will vibrate until the alarm function either corrects it's self, you correct it or you turn off the vibration function for that alarm. You can turn the function off by going to the first page of the SUM screen and turning off the music note. If the vibration continues then something else is still in alarm. Visual alarms cannot be turned off.

The first screen entered shows first page of current alarm conditions.

- To move between pages, use a short press of both buttons.
- To disable an alarm from vibrating the HUD vibration motor, use a short press of the right button to toggle the mode on and off. You will notice the music note symbol disappears. Visual and HUD alarms will still be apparent.

Below are tables of the alarm categories, and the specific alarms in each category:

OUROBOROS

Sum – Summary screen Alarms Tables

PPO2 Alarm Table – Highest Priority 1

Alarm	Description	Action
PPO2 OK	Average PPO2 reading from cells within +/-0.10Bar of setpoint	
PPO2 OFF	PPO2 control off	Bailout or manual PO2 addition required
PPO2 LOW	Average PPO2 reading from cells less than 0.10Bar of setpoint, but greater than 0.4Bar	Manually add o2. Check o2 addition valve. Check O2 cells reading correctly. Consider using bailout.
PPO2 HIGH	Average PPO2 reading from cells greater than 0.10Bar above setpoint, but less than 2.0Bar	Manually add diluent. Check o2 addition valve. Check O2 cells reading correctly. Consider using bailout.
PPO2 VLOW	Average PPO2 reading from cells less than 0.4Bar.	Manually add o2. Check o2 addition valve. Check O2 cells reading correctly. Use bailout.
PPO2 VHIGH	Average PPO2 reading from cells greater than 2.0Bar	Manually add diluent. Check o2 addition valve. Check O2 cells reading correctly. Use bailout.

Valve Alarm Table – Priority 2

Alarm	Description	Action
VALVE OK	Last feedback condition received from Valve OK.	
VALVE FAIL	No feedback condition received from valve solenoid on last fire.	Check battery levels. Check PPO2 levels. Consider turning RB off, and manually adding o2. Consider using bailout.
VALVE No chrg	Valve capacitor not been charged recently.	Check battery levels. Check PPO2 levels. Consider turning RB off, and manually adding o2. Consider using bailout.
VALVE Over chg	Valve capacitor being continually charged.	Check battery levels. Check PPO2 levels. Consider turning RB off, and manually adding o2. Consider using bailout.

Stack Alarm Table – Priority 3

Alarm	Description	Action
STACK OK	Stack time remaining for CO2 absorbent OK.	
STACK LOW	Stack time remaining for CO2 absorbent is running low.	Do not start new dive. Finish current dive as quickly and safely as possible. Consider using bailout.

Battery Alarm Table – Priority 4

Alarm	Description	Action
BAT OK		
BAT LOW	Battery level low.	Change ALL batteries in rebreather.

High Pressure HP Diluent and Oxygen Alarm Table – Priority 5

Alarm	Description	Action
HPdil OK	High pressure diluent cylinder gas above reserve level of 50Bar	
Hpdil LOW	High pressure diluent cylinder gas below reserve level of 50Bar	Consider using bailout. Switch to reserve diluent on off board manifold if available.
Hpdil RATE HI	Usage rate for diluent gas abnormally high.	Check for leaks. Do not dive. Consider using bailout. Check PPO2.
Hpo2 OK	High pressure o2 cylinder gas above reserve level of 50Bar	
Hpo2 LOW	High pressure o2 cylinder gas below reserve level of 50Bar	Consider using bailout. Switch to reserve diluent on off board manifold if available.
Hpo2 RATE HI	Usage rate for o2 gas abnormally high.	Check for leaks. Do not dive. Consider using bailout. Check PPO2.

OUROBOROS

Decompression Alarm Table – Priority 6

Alarm	Description	Action
DECO STOP	At correct depth for decompression within - 1.5m, +0m	
DECO VDEEP	Greater than 3meters below decompression depth	Ascend to decompression depth
DECO CLOSE	Within 3meters of decompression depth	Ascend slowly to decompression depth
DECO ALARM	Too shallow – Descend to deeper decompression depth	
DECO NoDEC	No ceiling	

Ascent Rate Alarm Table – Priority 7

Alarm	Description	Action
ASCENT OK	Ascent rate ok	
ASCENT FAST	Ascent rate too fast.	Slow down ascent

O2 Cell Alarm Table – Priority 8



O2Cell OK	All o2 cell sensors being used in PPO2 cell average computation	
O2Cell ERROR	One or more cells being excluded from averaging	Check PO2 individual cell readings. Check Backup display

Pre-Dive Alarm Table – Priority 9

Alarm	Description	Action
PRE-DIVE OK	All pre-dive checks completed	
PRE-DIVE ABORT	Rebreather went straight into dive mode without going through pre-dive checks	High risk of RB system not being set up correctly prior to dive
PRE-DIVE ABORT	Rebreather was aborted by user while going through pre-dive checks	High risk of RB system not being set up correctly prior to dive

Summary Screen List

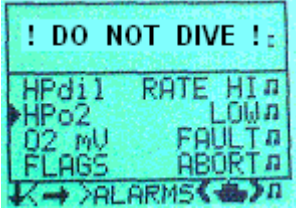
The screens are in order and displayed in several pages via a short push of both buttons.

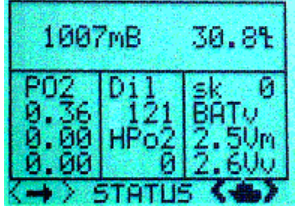
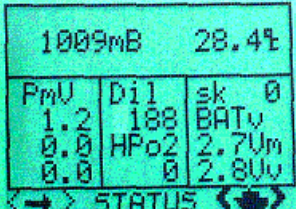
Summary Screen Description	Screen Example
<p>1. Current alarms. <u>This page displays which parameters are currently in alarm mode.</u></p> <p>a. If more alarms are active, then a second page shows a continued list of current alarms</p>	
<p>b. If no alarms are active, then 'System Operational' is displayed, together with the Atmospheric pressure and Temperature.</p>	
<p>2. Current status and readings of:</p> <p>a. Atmospheric pressure : surface only if no alarms</p> <p>b. Temperature : surface only if no alarms</p> <p>c. PO2 of O2 sensor cell 1,2,3</p> <p>d. HP diluent and O2</p> <p>e. Stack time used</p> <p>f. Battery voltage of Main (Vm) and Valve (Vv) batteries</p>	
<p>3. Current status and readings of:</p> <p>a. Atmospheric pressure : surface only</p> <p>b. Temperature : surface only</p> <p>c. mV reading of O2 sensor cell 1,2,3</p> <p>d. HP diluent and O2</p> <p>e. Stack time used</p> <p>f. Battery voltage of Main (Vm) and Valve (Vv) batteries</p>	

OUROBOROS

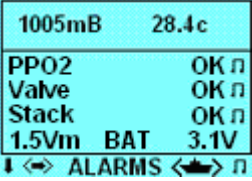
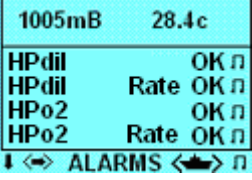
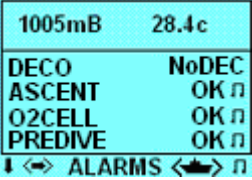
Summary Screen Description	Screen Example
4. Current alarm status of: <ul style="list-style-type: none"> a. Ppo2 cells b. Valve c. Canister duration d. Battery levels 	 <pre> 1005mB 28.4c PPO2 OK n Valve OK n Stack OK n 1.5Vm BAT 3.1V └┬┘ ALARMS ─┬┘ n </pre>
5. Current alarm status of: <ul style="list-style-type: none"> a. HP diluent contents b. HP O2 Contents c. HP diluent usage d. HP O2 usage 	 <pre> 1005mB 28.4c HPdil OK n HPdil Rate OK n HPo2 OK n HPo2 Rate OK n └┬┘ ALARMS ─┬┘ n </pre>
6. Current alarm status of: <ul style="list-style-type: none"> a. Deco stops b. Ascent rate c. Low mV from O2 cells d. Pre dive checks 	 <pre> 1005mB 28.4c DECO NoDEC ASCENT OK n O2CELL OK n PREDIVE OK n └┬┘ ALARMS ─┬┘ n </pre>

Ouroboros General Description and Background

History

Re-breathing systems are not new. The Military has developed and used such systems for decades. In the past (and even currently) these are simple analogue electronic or purely mechanical systems. Commercial diving and Search and Rescue operations have also operated simple systems.

All of these areas have for some time been looking for sophisticated replacements.



In addition to this, Sport divers have, for several years now, had a desire and need to dive for a longer time and to deeper depths.

With these different aspects of scuba diving in mind, the Ouroboros rebreather range has been designed for military, commercial, scientific, professional and sports diving. This has been achieved with a no-compromise approach to rebreather design, incorporating:

- **Reliability and Safety**
 - **The system can be used even with the failure of main electronics**
 - The systems have undergone a detailed Failure Mode Analysis (FMECA). This provides clear exposure of the interaction of failure scenarios. Outcomes of this analysis give feedback on potential high risk failure areas. All currently identified high risk areas have had design enhancements to achieve a higher level of robustness or an additional redundancy feature incorporated.

OUROBOROS

- **Incidents Review**

- A detailed review of rebreather diving incidents was conducted to help define the design parameters of the system. Key incidents that affected the design were highlighted as;
 1. Divers started the dive with their electronic control system off
 2. Divers started the dive with their oxygen turned off
 3. Divers descended with diluent off and then panicked when they could not find the manual addition
 4. Divers did surface swims on hypoxic diluents
 5. Divers did not pack the absorbent canister correctly or the design of the canister allowed CO₂ to bypass if O rings were incorrectly greased or assembled.
 6. With insufficient guidance on canister durations, people exceeded the duration limits
 7. Temporary floods made the breathing loop unusable
 8. Insufficient filtering produced oxygen solenoid and ADV failures
 9. Rubber hose attachment systems produced stress points which perished the hoses
 10. Electronics in the loop was affected by moisture
 11. Gas supplies were accidentally switched off
 12. Failures in the electronics made the unit unusable
 13. Divers become stressed at high work rates and the Human Computer Interface (HCI) became confused
 14. DCI occurred as a result of the units inability to maintain a near constant PO₂
 15. Divers did not follow pre-dive procedures

Specific design items have been added to avoid the above operational errors generating problems.

- **Ease of Maintenance**

- A no-tools approach has been the key criteria for routine maintenance functions
- The system is modular and breaks down into it's component parts easily

- **Simplicity of operation coupled with sophisticated alarms and monitoring**

- Once correctly configured the diver can simply breathe in and out while monitoring the automatic or manual addition of oxygen in the breathing loop
- The system advises the diver of any alarm conditions
- The on-board decompression computer in the main electronics control system keeps track of the actual PO₂ breathed by the diver. The integrated decompression algorithm is the same as used on the world standard VR3 decompression computer.

OUROBOROS

- **Flexibility in operation and Modularity**

For specialist applications the system can be configured with different duration canisters, different display options, download options and gas types and even different counter-lungs can be employed.
- **Redundancy in system failure solution scenarios**

Wherever appropriate, a single failure of an electronic component will not cause failure of the complete system. The Backup non-software PO2 monitoring system will function even in case of a main electronics failure. Manual gas bypass systems can be used in conjunction with the backup PO2 monitoring. As an option a fourth PO2 cell can be used with an external VR3 dive computer to monitor PO2 and advise backup decompression information, this coupled with an external stainless steel depth transducer makes the unit suitable for saturation diving.
- **Upgradeability**

Units can have PIN upgrades to different software levels. Software can be changed to cater for a specific operational requirement/diver interface.
- **Reprogram-ability**

Units can be re-programmed to incorporate major changes to software system

OUROBOROS

Overview of closed circuit rebreather components

The closed circuit rebreather allows the diver's exhaled gas to be "scrubbed" clean of exhaled carbon dioxide and re-breathed, coupled with a controlled variable addition of oxygen and diluting gas. The closed circuit rebreather provides an optimised breathable gas for divers through a wide depth range for a given pair of on-board gases. This can be further extended with additional hot swappable external diluent mixes.

The main components of the system are:

- a) **Closed circuit breathing loop** to provide breathable gas to the diver and in the process remove carbon dioxide from the diver's exhaled gas.
- b) **High-pressure Oxygen cylinder** to allow addition of oxygen into the breathing loop to compensate for oxygen used by the diver's metabolism.
- c) **High pressure inert gas Diluent cylinder** with low oxygen content to allow the oxygen to be diluted, and thus remain at a non-toxic pressure. The diluent gas can be air for depths up to around 50 meters. Below this, Helium is added to the gas and the oxygen percentage lowered.
- d) **A mechanical and electronic control system** to facilitate the addition of oxygen into the breathing loop to maintain a breathable and optimized oxygen level.

Improvements incorporated in Ouroboros

The Ouroboros design for the rebreather incorporates two main improvements over previous industry designs.

The first is mechanical, whereby a more robust breathing loop system, integral (protected) counter-lungs and simpler maintenance provide an intrinsically safer system for divers to become familiar with and operate.

The second is in the electronics computer systems for control, logging and decompression requirements analysis.

For the first time in a rebreather, the electronics system has been developed from an existing leading dive computer electronics company. Thus control, system setup, decompression modeling and alarm systems have all evolved from a system that incorporates a knowledge base and proven design for diver interaction with underwater computer systems. On top of this, the modularity and reprogram-ability of the software systems provides a future-proofing of the system design.

Some rebreathers already in the market have a relatively low-budget computer system, with correspondingly fewer features or options that facilitate the range of diving techniques and scenarios employed by divers around the world. They are therefore inhibitive and have a relatively small market.

OUROBOROS

In keeping with a philosophy of reliability, safety and diving style variance, the Ouroboros can also function completely without the main electronics computer system. The Ouroboros incorporates a Backup, independent PO2 display system that shows the mV and normalized PO2 reading for each cell. This provides an alternative and/or backup system that gives the diver adequate information on which to perform or complete a mission, manually controlling the setpoint through the manual O2 addition valve.

A breathing circuit with a low resistive work of breathing (WOB), dual back mounted counter-lungs, partial flood recovery and an efficient radial canister completes the system.

Although the design is new, the experience of the personnel concerned encompasses knowledge and experience gained in over 15 years of development and use of underwater electronic products, as well as in extreme diving itself. The product is an evolution of the best parts of rebreather design, coupled with a fully upgraded full function control system.

OUROBOROS

Ouroboros Mechanical Systems

Design Criteria

The mechanical system has been designed with several key features in mind.

1. Reliability
2. Breathing performance and pathways
3. Maintenance
4. Simplicity of operation (particularly in multi-task situations)
5. Flexibility in operation and Modularity

1. Reliability

As the unit provides a breathing system for the user in a non-air environment it is vital it does this reliably, and in a manner that is tolerant of system faults should they occur while diving. This is achieved by:

- a. The fundamental philosophy of having a mechanical system, which can work in conjunction with **or separately** from the electronics, allowing the diver to control gas input even if there is a complete main electronics system failure.
- b. Use of tried and tested electronics and software from an existing dive electronics manufacturer

2. Breathing Performance and Pathways

This is a very clear-cut area and is laid down in a CE standard. The unit has already undergone testing in accordance with EN14143:2003. This test not only covers breathing parameters, dive duration and oxygen control but also includes the field of user interaction and robustness. At this stage the unit operates in excess of many parameters laid down by CE.

All components of the breathing loop are designed to give maximum gas flow while providing total robustness. All gas handling lines are rated at 10 times their usage pressure and where required oxygen cleaning standards are adhered to.

The unit has an Oxygen and a Diluent (make-up gas) pathway. The two meet inside the co2 absorbent canister, which then feeds the counter lung system from which the diver breathes.

OUROBOROS

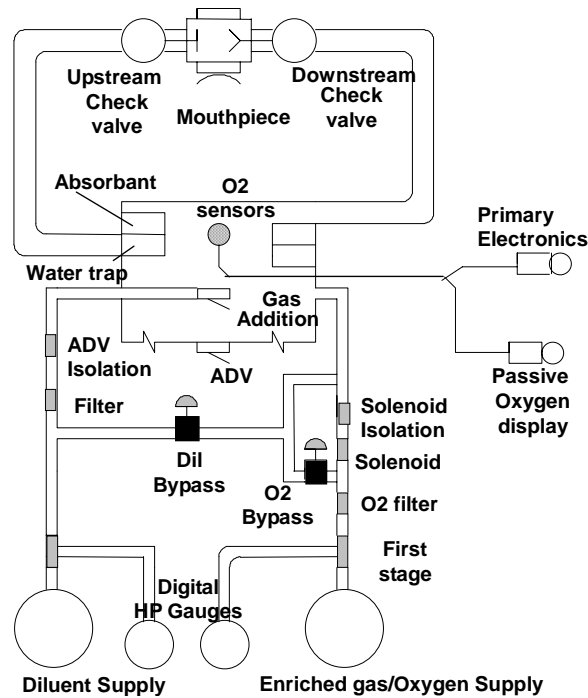

The high pressure gas system comprises two storage cylinders (one for each gas). Each cylinder feeds a pressure regulator (one oxygen and one diluent). The oxygen regulator then feeds:

- The electronically controlled solenoid injection valve for automatic injection of oxygen (via its emergency isolator).
- The manual oxygen injection valve (the Bypass system)
- A gas-switching block to allow an external cylinder of oxygen to be plugged into the system to increase the usage duration.

The high pressure diluent regulator feeds:

- The automatic diluent addition to maintain a breathable volume of gas (via its emergency isolator).
- The manual diluent addition system (the Bypass system)
- A gas switching block to allow an external cylinder of diluent to be plugged into the system to increase the usage duration

Both oxygen and diluent are then mixed in the co2 absorbent canister in the correct ratios. The canister then connects to a pair of collapsible variable volume counter lungs, which feeds the user's mouthpiece via a ballistic nylon hose system.

On each shoulder (integral with the safety harness) are one of each of the afore mentioned Bypass and additional gas plug-in blocks.

High pressure gas monitoring is achieved via electronic sensors, which feed into the main electronics. This provides feedback to the user on remaining volume and usage rates.

OUROBOROS

The breathing mouthpiece can be isolated to allow the diver to switch to a bailout alternative emergency breathing system.

3. Maintenance

The concept of the design is to provide a 'no tools' ethic. For [in-field operations](#) it is vital that maintenance can be carried out without specialist hardware. This has the added advantage of simplifying the system.

Each individual component can be stripped by hand for maintenance and cleaning. Many parts in the gas control system are readily available as standard components from gas fitting manufacturers.

It is the nature of such systems that on a daily basis they need a level of disassembly for between-use storage. Again the unit allows for this in a 'non-tools' environment.

4. Simplicity of Operation

In any life-support system it is paramount that general operation (especially in a task loaded environment) is as simple as possible. This is partly catered for in the electronic control system to be detailed later.

The Ouroboros' simplicity starts with **the complete manual override capability of the electronic control system**. Both oxygen and diluent can be manually added to the breathing loop via the gas blocks mentioned. The appropriate levels being monitored on **the independent back-up oxygen display**. All gases can furthermore be isolated to stop addition (manual or automatic) via isolating valves.

The only other interaction with the mechanics required during use is to isolate the mouthpiece, which is done via a simple ¼ turn valve.

Any excess water entering the system is automatically discharged overboard or can be manually purged.

The CO2 absorbent canister uses a **self-packing system** ensuring that the absorbent material stays tightly packed preventing a bypass of the material and allows for rapid pre-dive assembly.

Once the system has been correctly understood and assembled, the diver simply breathes in and out while monitoring the automatic or manual injection of gas.



5. Modularity and Flexibility in operation

The system can be configured with different duration canisters, different display options, download options and gas types. For specialist operations, the use of different canister sizes can enhance the use-ability of the rebreather in a range of different scenarios. For example, a smaller canister with corresponding smaller height of the back of the diver would suit less extreme divers not requiring the full canister and cylinder durations.

OUROBOROS

Rebreather Component Layout

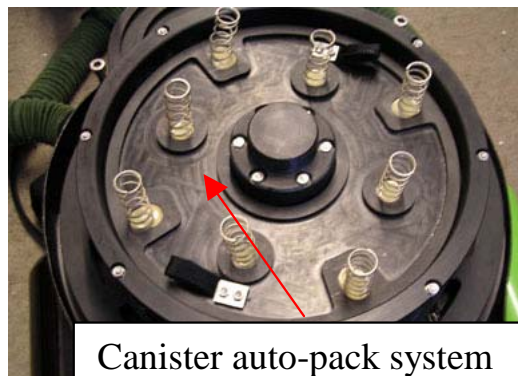
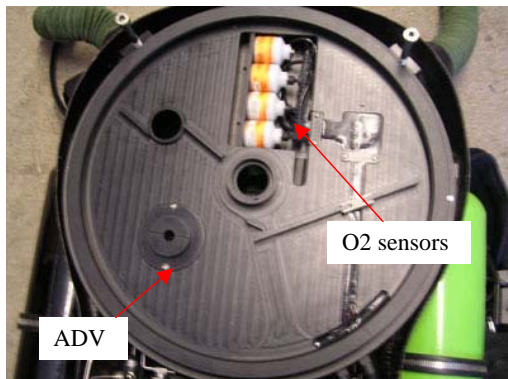
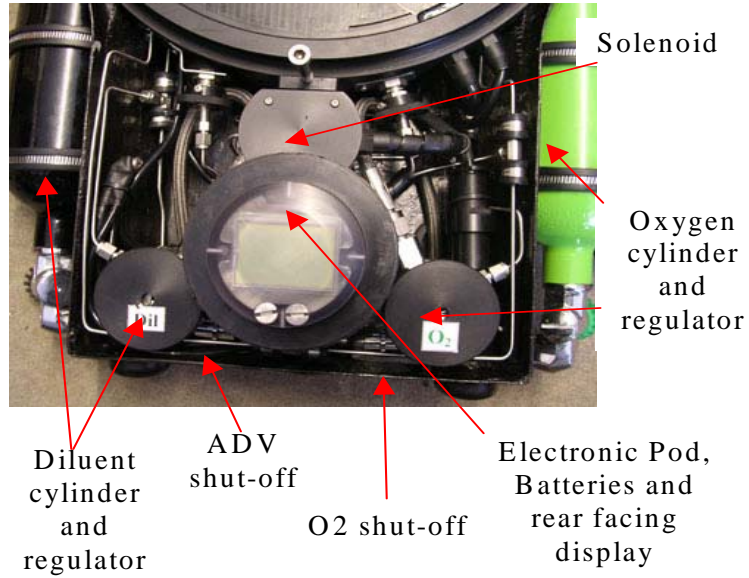

OUROBOROS

System Block Diagram – High Pressure/Medium pressure Gas piping

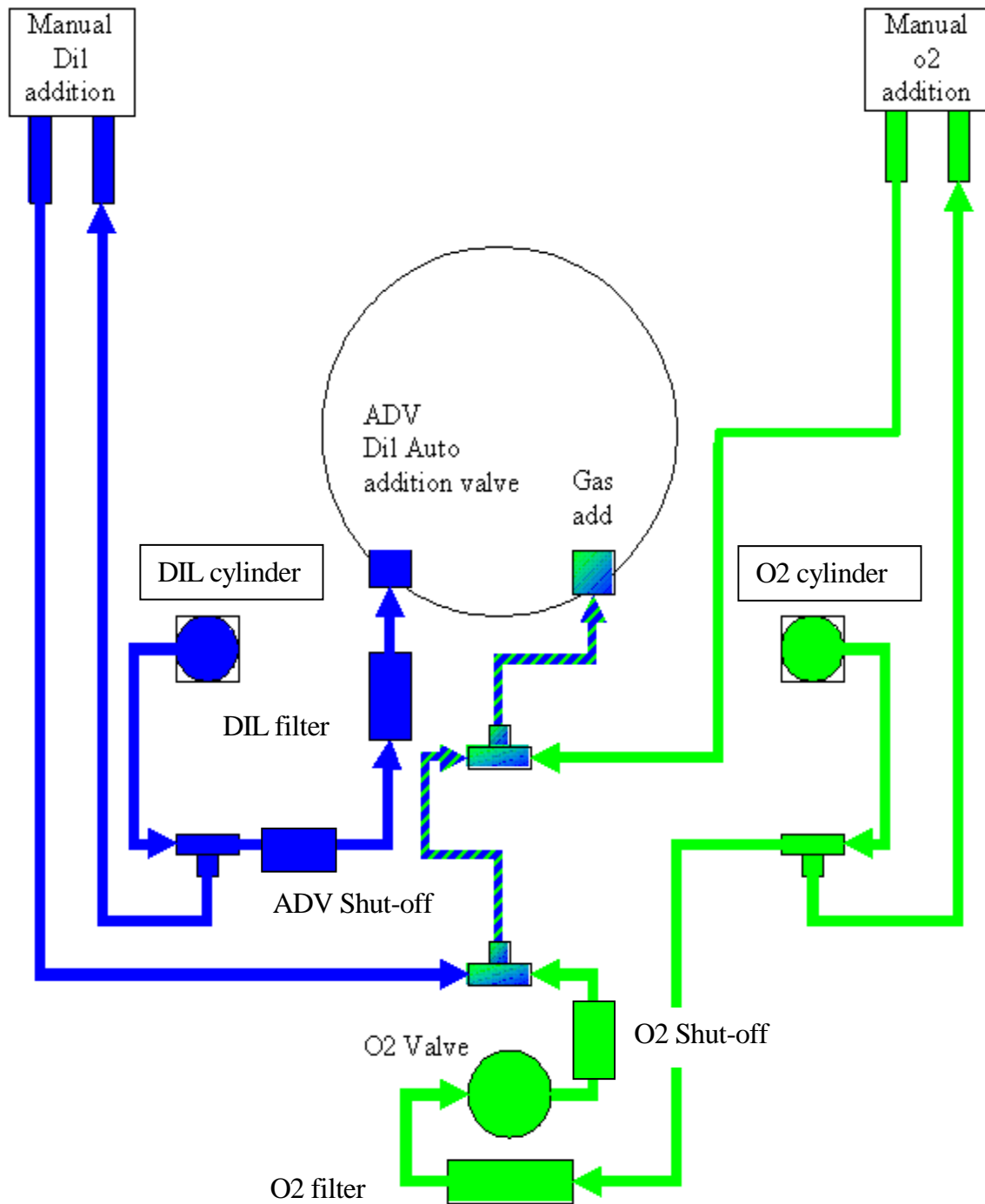

OUROBOROS

Ouroboros Electronics and Computer systems

The electronics and computer systems have been designed with particular criteria in mind and explained below. Some of these are relatively obvious, but have been implemented based on the considerable experience and refinement of designs tested and tried over years of experience with in-house and third party equipment.

This has produced the appropriate balance between:

- Sophistication
- Ease of use
- Automation / Manual override
- High level /Low level status presentation
- Alarm condition presentation
- Reliability

This ensures the diver is not over burdened with too much information or controls, while providing detailed status information, if required, to perform more complex maintenance or emergency procedures.

Design Criteria

The electronics and computer systems have been designed around six main criteria:

1. Safety/Reliability
2. Redundancy
3. Maintenance / Serviceability
4. Modularity
5. Upgradeability
6. Re-program-ability and PC interface

1. Safety/Reliability

For obvious reasons, the reliability of the system underwater in providing a breathable gas and feedback in the system operations are of paramount importance. Although the diver would routinely carry backup and have bailout contingency plans, the system wherever possible should provide a breathable gas in as extreme an environment as is feasible.

The external electronic cables have a double sheath. Cables can be cut or punctured without risk of flooding or disabling the main control system. Should any of the front facing displays fail, the in-board control system will maintain the life support functions, but obviously, functionality will be reduced. If a severed cable results in loss of PO₂ or external readings, then these will be alarmed for on the active displays.

A more complete analysis of the safety considerations are described in Appendix 1 and Appendix 2, which contains an extract of the Technical documents used in the CE approval documentation submission. Appendix 1

OUROBOROS

focuses particularly on overall safety design. Appendix 2 focuses on software/programmable systems.

2. Redundancy

In case of main system failure, the redundancy in providing independent backup information allows the trained diver to manually control the system and get out of the water safely.

3. Maintenance / Serviceability

Battery, oxygen partial pressure cell and system status are provided to the diver, so that these can be changed when the levels fall below design limits. In particular, the maintenance is simple, and reduces pre/post service/maintenance times.

4. Modularity

The electronics systems are designed to allow diving with all or only parts of the available systems connected. For example the unit can be supplied with or without the following items:

- Head Up Display (HUD)
- High Pressure (HP) sensors
- 4th PO2 sensor and additional VR3 decompression computer
- In-water communications link
- Rear facing average PO2 display and mimic HUD
- Off-board gas supply plug-ins

On top of this, different diving styles can also be accommodated. For example only the HUD can be used for diving, but the Primary display or PC link is used for initial system setup. This style has been adopted for some military or other minimal clutter diving missions.

5. Upgradeability

This allows different software options to be activated by PIN number. Thus units can be easily field upgraded should this be required. For example, use of different diluent gasses such as tri-mix helium gasses can be activated as an upgrade from Nitrox only systems

6. Reprogram-ability and PC interface

The software can be fully reprogrammed using a PC to download the new versions. This can be done in the field, or back at the factory. This provides for new features as well as decompression algorithm or other diving style rules to be adapted throughout the life of the product. It also provides a base on which specific customized functionality can be achieved for different clients with specific diving procedures and styles. See section [Re-programming system](#). The Ouroboros can also connect to the PC to download dive data and revise settings within the rebreather. See [Download Dives](#) section.

OUROBOROS

Software and Electronics key functional points

1. Key design issues:
 - a. Chance of free flow oxygen limited by electronics design.
 - b. Units will turn on and maintain breathable gas in as many automatic modes as possible to keep operation as simple and intuitive as possible
2. System will turn on:
 - a. when wet
 - b. when at depth greater than 6m at 1000mBar atmospheric – 1.6Bar absolute pressure. Therefore the turn on depth will vary will altitude for this mode of operation.
 - c. when activated with a Primary display switch
3. System will turn off:
 - a. When manual turn off selected from front dry screen
 - b. After 50 minutes after dive if dry, and not diving and in dry front screen
 - c. After 50 minutes if set point has been turned on, but still dry
 - d. After 5 minutes if set point not on, and dry
4. Setpoint will turn on:
 - a. Automatically when dive mode activated
 - b. When manually selected from front dive screen
5. Setpoint of 0.4 will be maintained if dive setpoint is not activated. This means that the unit will keep the gas in the breathing loop breathable when the unit is on, and the O2 cylinder is turned on.
6. Unit will go into dive mode:
 - a. When depth greater than 1.5m when rebreather is on
 - b. When manual chamber dry dive selected
 - c. When rebreather is off - depth greater than 6m at 1000mBar atmospheric – 1.6Bar absolute pressure will turn the unit on, and put the rebreather into dive mode. Note that this will abort Pre-dive checks screens – this is not advised, but is included as a safety issue to ensure rebreather is on in as many user error fault scenarios as possible. See section [Pre-dive set-up](#) for correct turn on procedure. Therefore the turn on depth will vary will altitude for this mode of operation.
7. The Ouroboros will warn on the primary display, and mimic on the heads up and rear facing displays. See [Table of Alarms](#).

Main sub-systems

The main parts in the electronics and computer systems are:

1. Sensing of Partial pressure of Oxygen in the breathing loop delivered to the diver.
2. Firing of Solenoid valve to increase Oxygen level in breathing loop as required, based on control algorithm in microprocessor software system.
3. Microprocessor system to provide software platform for control and sensing of external devices and sensors.
4. Software system. This has derived from the VR3 dive computer system, and thus includes sophisticated features, and ergonomic design based on considerable research and development already put into the dive computer product. This makes for the most featured, integrated and adaptable rebreather product on the market to date.
5. Status / Alarm warning system to provide LCD full status display as well as separate high level LED display of key parameters.
6. Backup secondary system, separate to microprocessor system to provide breathing loop Partial pressure of oxygen display in case of failure of main system, and as confidence in main system operation.
7. Battery power supply systems to supply power to the electronics computer and valve control systems. An intelligent power sharing system is employed in the event of a single cell failure.
8. Remote data download and reprogramming system.
9. General ancillary systems monitoring, to provide confidence and maintenance information.

The block diagram below shows the interconnectedness of the above systems.

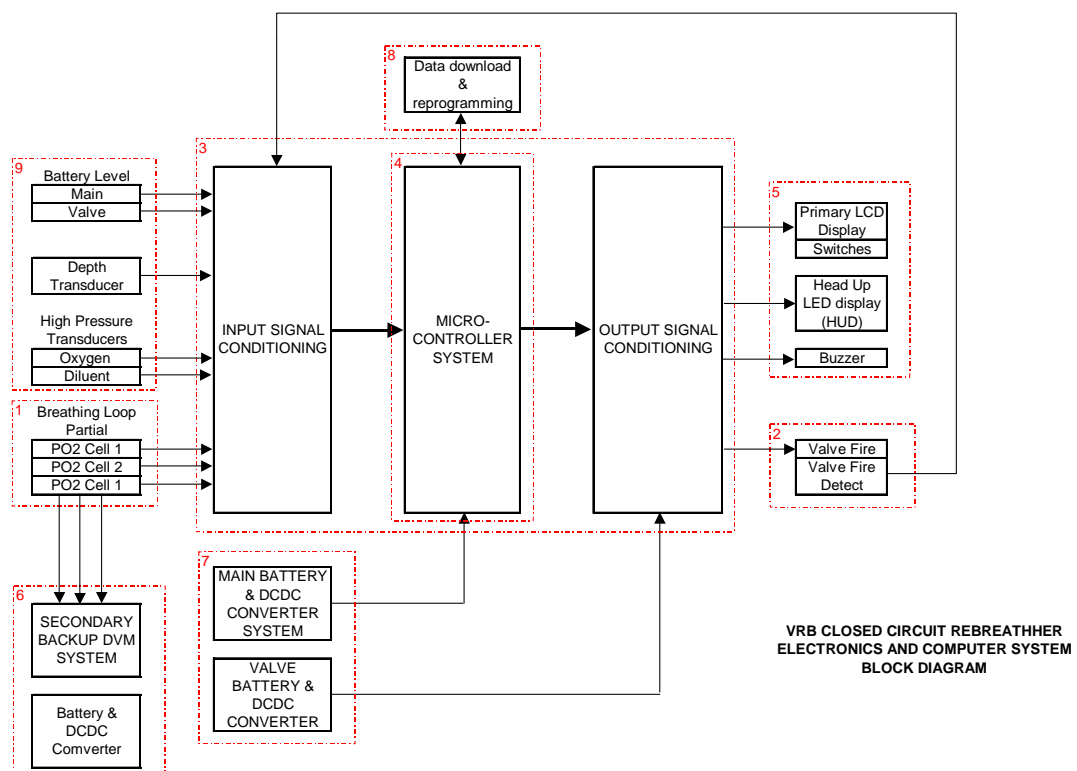

OUROBOROS

1. Sensing of Partial pressure of Oxygen

This detects and conditions the current partial pressure of oxygen in the breathing loop delivered to the diver

- 1.1. For redundancy and averaging, there are three separate oxygen cells, each consisting of a standard Class B Oxygen sensor cell from Teledyne. The output of each of these cells is buffered to feed both the main electronics and back up Backup display.
- 1.2. In the secondary Backup display, the buffered feeds input into three separate Digital Voltmeter LCD displays via a potential divider for calibration purposes.
- 1.3. Due to the temperature variation and life span of the cells, [calibration](#) has to be carried out periodically. In the Main electronics this is a software function. In the secondary Backup display there are individual variable resistors that can be accessed via a removable waterproof pressure cap.
- 1.4. Of particular note in this design are:
 - 1.4.1. Dual feed of cell output. If the path to the main electronics is shorted out, the signal will still be available on the Backup unit. This also applies vice versa.
 - 1.4.2. Sensor module in rebreather front end can be removed easily without special tools, to keep the sensors dry and out of adverse conditions when not diving.

2. Firing of Solenoid valve

Firing of the Solenoid valve injects oxygen into the breathing loop to compensate for oxygen used in the diver's metabolism. The injection is based on the control algorithm in microprocessor software system

- 2.1. The solenoid valve that adds oxygen from the High-pressure cylinder into the breathing loop provides a vital role. However, there is also a manual mechanical addition valve. The worst-case failure scenario for the solenoid valve is for it to stay open, thereby potentially adding oxygen to fatal levels. Therefore, considerable design and development has been put into providing failsafe electronic circuits that minimize the chance of the valve staying open in the electronic domain in driving the device.
- 2.2. Due to the critical control nature of the solenoid, an additional circuit detects the solenoid valve fire sequence. This triggers an input port into the microprocessor giving feedback that the solenoid has been fired and turned off again within a specified time period. If this signal is not detected in the correct time period, a warning is given to the diver by flashing the Valve fire LED on the Head Up Display (HUD), and by flashing the backlight on the main display, signifying a general alarm. In addition, if the battery levels fall to critical levels, the Valve may not be firing fully. This condition also triggers the Valve fire LED to flash.

3. Microprocessor and signal conditioning system

This provides a platform for the software system for the control and sensing of external devices and sensors

OUROBOROS

- 3.1. This system uses a very large scale integration single chip micro-controller. This ensures a high level of reliability, as fewer external connections are required to make the complete system.
- 3.2. The micro-controller requires input and output signals to be buffered or conditioned to adapt them to and from the appropriate format of the external devices and sensors. Thus amplifiers and buffers are used in addition to the main controller. These buffers also provide for isolation of common signals, so that a break or shorting of individual cables, wherever possible, does not bring down the operation of the total system.

4. Software system

This has derived from the VR3 dive computer system, and thus includes sophisticated features, and proven ergonomic design based on considerable research and development already put into the dive computer product. This makes the most featured, integrated rebreather product on the market.

Features include:

- 4.1. Cell level monitoring / auto or manual disable of non-calibrated sensor
- 4.2. Data and Alarm Logging
- 4.3. Decompression software
- 4.4. Diver gas setup feature, available also when diving
- 4.5. Full on screen dive data, including:
 - Depth
 - Dive Time
 - Decompression Requirements
 - Optimum gas advice
 - Maximum depth
 - Temperature
 - CNS toxicity
 - PO2 monitoring

5. Main Display, Status and Alarm warning system

This provides a primary LCD full status display as well as separate high level HUD LED display of key parameters, rear PO2 display, and a vibration motor mounted in the HUD

- 5.1. The primary user interaction is through a back lit LCD display and two reed switches, which can be used underwater. These provide access to all functions and all mission critical status information is available through accessing screens and sub-screens.
- 5.2. The backlight can be setup up to work in five ways, ON for 10 seconds after any switch press, ON after a switch press when diving only, OFF always, ON mode when diving only, and timer mode when diving only. The brightness of the backlight creates a very even light that allows viewing under all external light conditions.
- 5.3. A separate LED display module provides 4 LEDs that reflect the status of key diving and system parameters. This has been designed small enough to be used as a Head Up Display (HUD). This is particularly useful as a basic GO/NO GO guide. The LEDs represent status of:
 - Partial pressure of oxygen breathability

OUROBOROS

- Decompression stop requirement
- Solenoid valve fire
- General alarm for problem with any other sub-system, e.g. battery, High Pressure gas supply

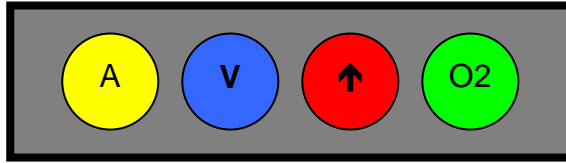

The table below shows the alarm states and corresponding HUD warnings.

Table of Heads Up Display (HUD) Alarms

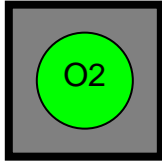
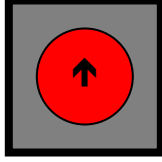
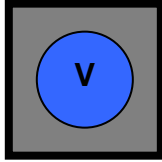
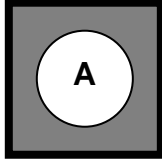
Warning	HUD LED operations		
PO2			
PO2 within 0.10 bar of setpoint	Green LED on solid		
Very Low PO2	Green LED slow flash		
Low PO2	Green LED slow flash		
High PO2	Green LED Fast flash		
Decompression Ceiling			
At decompression stop within -/ +1m	Red LED on solid		
Deco ceiling violated stop	Red LED fast flash		
Deco stops required	Red LED slow flash		
Solenoid Valve			
Valve electrically activated OK	Blue LED single short flash		
Valve electrical activation fault	Blue LED fast flash		
If valve mechanically stuck, valve activation may show ok, but valve still stuck open or closed	HP rate and PO2 alarms will trigger		
General Alarms			
HP alarms			
Low HP content	White LED slow flash		
High HP usage rate	White LED Fast flash		
Low HP usage rate	White LED Fast flash		
Ascent Rate			
Fast ascent rate	White LED Fast flash		
Batteries			
Low Main Battery	White LED slow flash		
Low Valve battery	White LED slow flash		
Pre-dive check			
PRE-DIVE aborted	White LED slow flash		
PO2 cells			
Low mV reading	White LED slow flash		
Due to many alarm conditions using this White LED, the Primary display (SUM screen) should be checked to determine which fault is activating the alarm			

- 5.4. The Ouroboros has a display on the back of the unit that faces to the rear. This displays the current PO2 of the system, as well as a mimic of the HUD LEDs. This gives information to the dive partner, thus providing extra support and confidence in system operation among the dive team.
- 5.5. A Vibration motor provides warning at the HUD/mouthpiece, and is used in conjunction with the LED and LCD screen alarms. The vibration alarms can be disabled from the primary LCD display unit. A vibration motor has been used in preference to a buzzer, as other

OUROBOROS

noises often detract from the hear-ability of the buzzer. Also the vibration feeling can still be effectively recognized by the diver in cases where hearing may have been significantly impaired.

6. Backup secondary system

This system is separate to the microprocessor system to provide breathing loop Partial pressure of oxygen display in case of failure of main system, and as confidence in main system operation.

- 6.1. This display is designed with a completely different component set to the main electronics. It also has no software. Therefore, the possibility of it failing under the same conditions as the main electronics are much reduced. Three separate Digital Voltmeter LCD displays are used in-conjunction with variable resistors as a potential divider used for calibration purposes.
- 6.2. Due to the temperature variation and life span of the cells, calibration has to be carried out periodically. In the secondary back up display there are individual variable resistors that can be accessed via a removable waterproof pressure cap.
- 6.3. On top of this there are two switches, which allow:
 - The unit to be turned on for approx 10 seconds
 - Provide a bypass of the calibration circuit, to check on the raw milli-volt reading from the Oxygen cells. This allows a check on the health of the cells, based on a specified acceptable range for a given oxygen level from the manufacturers

7. Battery power supply systems

This provides power to the electronics computer and valve control systems, together with a totally separate supply for the secondary backup display unit.

- 7.1. This has been designed around two main issues:
 - 7.1.1. Battery type must be user changeable, and obtainable around the world
 - 7.1.2. Batteries must be reliable and last as long as possible.
- 7.2. From the above two points, rechargeable batteries are not used, as can become unreliable depending on the charging regime used.
- 7.3. DC-to-DC converters are used to create the required internal stable voltages from the battery sources. This means that the cell ampere-hour capacity is efficiently utilized. As the battery voltage drops with age and load, the DC-to-DC converts bring the voltage up to the required levels for both valve firing and main electronics operation.
- 7.4. There are three separate battery circuits.
 - 7.4.1. Main electronics
 - 7.4.2. Valve firing circuit
 - 7.4.3. Secondary backup display.
- 7.5. This ensures that no single cell failure will disable the whole system. On top of this, the main electronics is fed from the Valve firing battery as a backup source in case of main battery failure. Thus the main electronics will operate if either the Main or Valve firing battery is operational. The 2 cell combination provides a nominal 3V supply for

OUROBOROS

the Main Electronics operation, including Valve firing and main computer. This is backed up by a single cell 1.5V source that will come into operation only when the 2 cell battery set is failing. However, to ensure the most reliable operation, ALL BATTERIES SHOULD BE REPLACED AT THE SAME TIME, WHENEVER A BATTERY LOW ALARM IS GIVEN.

<p>ALL BATTERIES SHOULD BE REPLACED AT THE SAME TIME, WHENEVER A BATTERY LOW ALARM IS GIVEN</p>
--

8. Remote data download and reprogramming system

Incorporated into the design is the ability to communicate with the rebreather from an external device. This allows retrieval of dive data from the rebreather, and the re-programming of the complete system. This provides for the following key features:

8.1. Retrieve dive profile data including:

- 8.1.1. Depth
- 8.1.2. Temperature
- 8.1.3. Partial pressure of inspired oxygen
- 8.1.4. Time
- 8.1.5. Gases used
- 8.1.6. Time and Date and Duration of dive
- 8.1.7. Battery levels
- 8.1.8. High Pressure contents
- 8.1.9. Alarm conditions

8.2. Upload gas and system setup data to Rebreather from PC. This is useful on projects where a number of rebreathers may need to be setup to identical or similar states. Also the tracking of exactly how the rebreathers are setup is maintainable on a PC log.

8.3. The software in the rebreather can be completely changed and upgraded using the reprogramming capabilities of the on chip Flash reprogrammable memory on the Micro-controller. This also provides a sophisticated system to create specific versions tailored to individual client needs.

9. General ancillary systems monitoring

This provides confidence and maintenance information of all the support systems in the rebreather.

9.1. Monitoring of the following signals provides feedback to the diver, both while diving and during preparation on the surface, as to the condition and content of the resources used by the system during the dive:

- Main Battery Level for Electronics system operation
- Valve Battery level for Valve and backlight operation
- Current Depth or Atmospheric reading
- High pressure content of Oxygen cylinder
- High Pressure content of Diluent cylinder

OUROBOROS

System Block Diagram – Electronic System

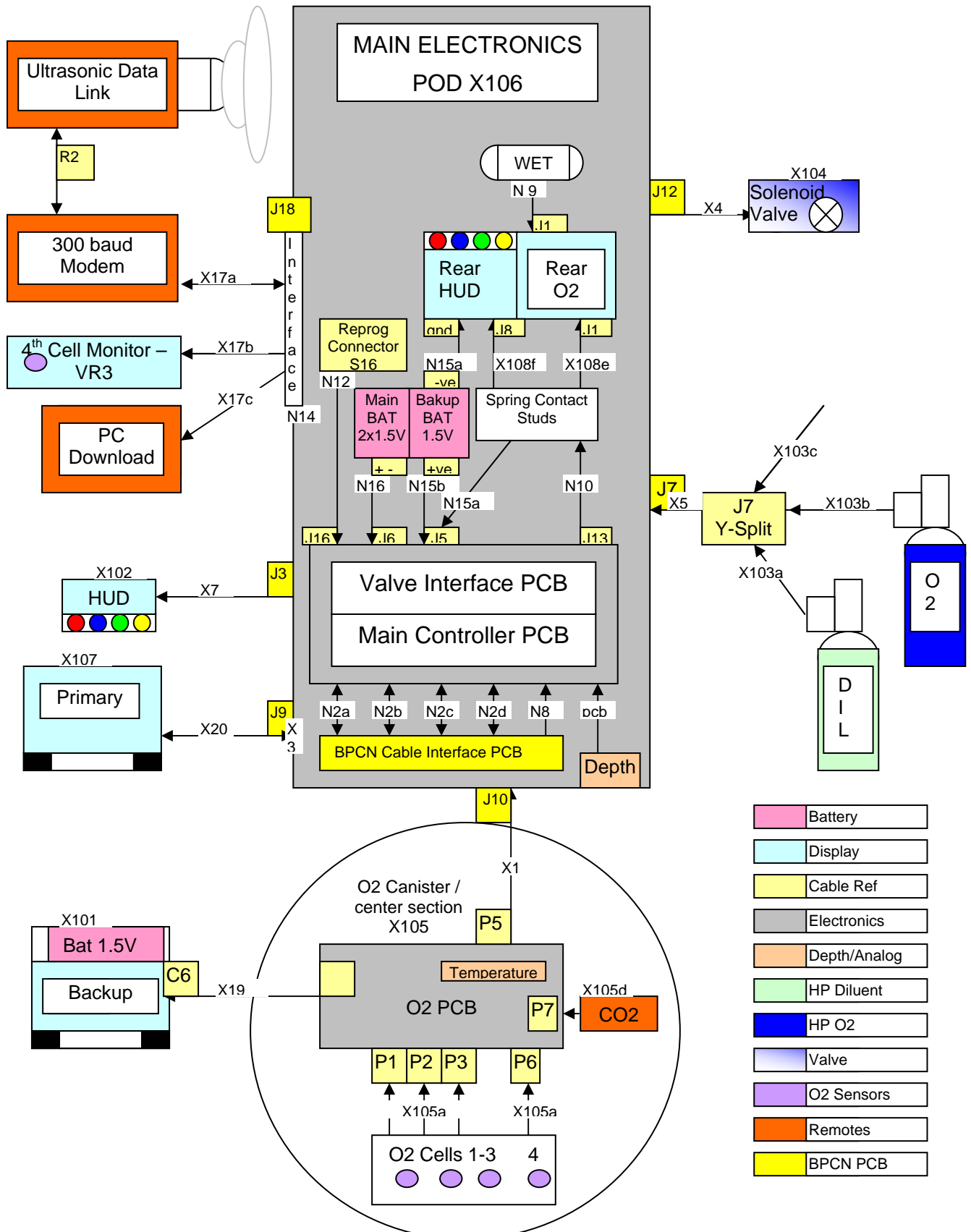

- Battery
- Display
- Cable Ref
- Electronics
- Depth/Analog
- HP Diluent
- HP O2
- Valve
- O2 Sensors
- Remotes
- BPCN PCB

Failsafe of oxygen addition valve

This section provides a detailed description of the ways in which the solenoid valve operation has been considered in various failure modes.

The oxygen addition solenoid valve allows the micro-controller system to automatically add oxygen to the breathing loop when the detected Partial pressure of oxygen level falls below a configurable target level.

The oxygen addition valve has two main failure types:

1. Valve stays permanently shut
2. Valve stays permanently open

These scenarios are discussed below:

1. **Valve stays permanently shut**

From a diver safety point of view, a permanently shut valve causes a gradual decrease in oxygen level that is warned of in the display systems. This failure scenario can happen due to an electronics failure, or a mechanical failure of the valve. This failure mode is gradual, and a diver has time to sort out this by using the manual addition valve on the rebreather rig. This manual valve has no connection to the electronics micro-controller control system, so is isolated from any impacts of electronics failure.

2. **Valve stays permanently open**

This failure scenario can cause a rapid increase in the partial pressure of oxygen level, which can cause the diver to **quickly** become incapacitated and ultimately die. This failure type could be caused by a mechanical or electronics failure. Due to the rapid nature of the onset of diver problems from this failure type, it has been given special attention to reduce the risk of this type of failure from an electronics and mechanical standpoint. The following list gives the potential scenarios and method for reducing probability of failure:

- a. **Valve stuck open due to debris under the valve mechanism**

This has been guarded against by the installation of a filter in the O2 addition line. However, should this still happen, the diver can shut off gas using the main cylinder shut off – see below.

- b. **Software and Electronics drive circuit failure.**

This has been guarded against by a failsafe electronic circuit that ensures no single component failure can force the valve to stay on.

In the event of either of the failures above happening, despite the system precautions, the diver can shut down the oxygen supply by turning off the oxygen supply at the main cylinder. Alarms on the HUD, Rear facing O2 display and Main display will show high

OUROBOROS

Partial pressure O₂ warnings, and the backlights will flash. The piping system has been designed with a minimum of reservoir, so that turning of the cylinder O₂ supply will quickly stabilise the O₂ level. The diver can then add diluent to bring the O₂ back down to safe limits.

Re-programming system

The electronics pod system can be re-programmed using a PC and a hardware interface adaptor.

The components consist of:

- Hardware interface adaptor
- Power supply
- RS232 cable
- Parallel port 25 way cable
- Molex 12way to 9pin female cable
- Molex male-male plug

1. Plug RS 232 cable into PC.
2. Plug male end of RS232 cable into interface adaptor.
3. Plug Parallel 25 way cable into PC.
4. Plug Parallel 25 way cable into interface adaptor.
5. Plug 9 pin female of Molex/9pin cable into Hardware adaptor.
6. Remove battery lid from electronics pod
7. Connect molex connector to mating interface of Fisher connector using plug adaptor.
8. Run Reprogramming software on PC. Choose option Board 1. Choose file to be uploaded – normally monitor.sog – from file list box.
9. Connect power supply to mains, and plug 5v dc into Hardware interface adaptor.
10. If no external power, internal batteries can be used.
11. Switch hardware interface on switch to external power, or batteries as required.
12. Click program button on PC software. String 0AAC0 should appear in top text box of PC software. After 10 seconds a string of 1A1A.. should appear in main text box. If this does not happen and the text boxes stop changing, re-press Program button.
13. When system is re-programming, do not use any other function on the PC. Wait till programming is done. Bar graph will move gradually fill as programming progresses.
14. After system has been programmed, click Run button. Check for 'hello world' to appear in main text box. Check system is running on primary and HUD.

OUROBOROS

Ouroboros PC Link for Dive Downloading and System Configuration

The Ouroboros can be connected to a PC software system to perform the following tasks:

1. Download dives
2. Upload gas configuration
3. Change data recording interval

The software is currently only available for Microsoft Windows XP operating systems.

Installation

Insert the CD installation disk into the PC. If the disk does not automatically start the setup program, choose the setup command from the CD drive letter on the PC. The drive types are listed in the Windows - My Computer - window screen.

To install, choose the install option, and accept the terms and conditions to proceed.

After installation, an icon called Ouroboros will appear on the windows desktop, and also under the start menu group called Ouroboros Rebreather. Also installed in this group is a soft copy of this manual.

Click on the icon Ouroboros to start the PC software.

Operation

The first start up screen displays a list of buttons of the most common functions. Other functions can be accessed from the pull down menus.

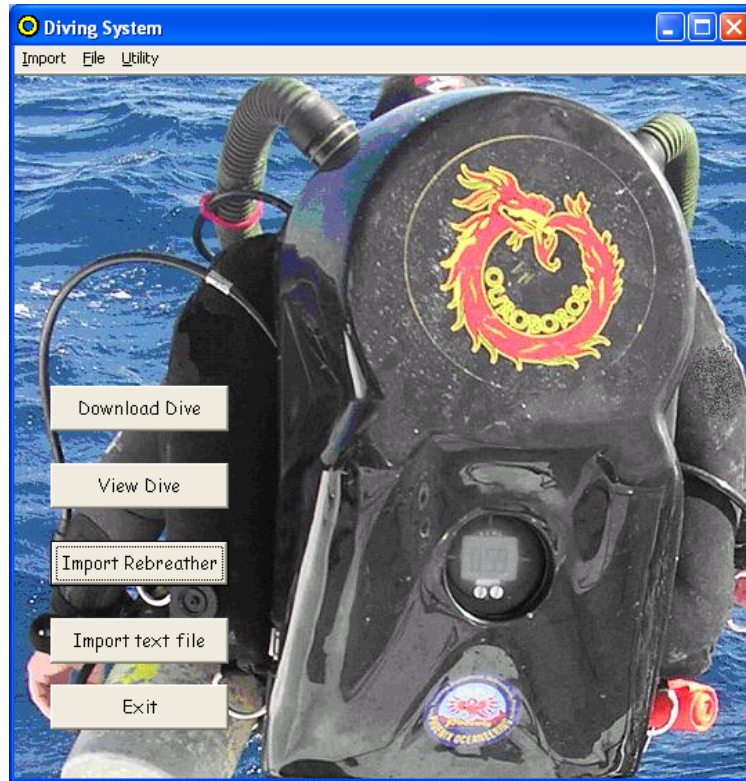

1. [Download Dives](#) – This automatically downloads files into the database. The Import Rebreather has to be used first to connect to the rebreather and get the dive data from the rebreather.
2. [View Dives](#) – This allows viewing of the downloaded dives. Summary and Log type data can be added to complement the downloaded data.
3. [Import Rebreather](#) - connects to the rebreather to download dive from the rebreather, as well as perform other PC to rebreather functions.
4. [Import Text File](#) - allows manually into the rebreather.
5. **Exit** – Exits the software.

The detailed function of these buttons is explained below.

OUROBOROS

Import Rebreather

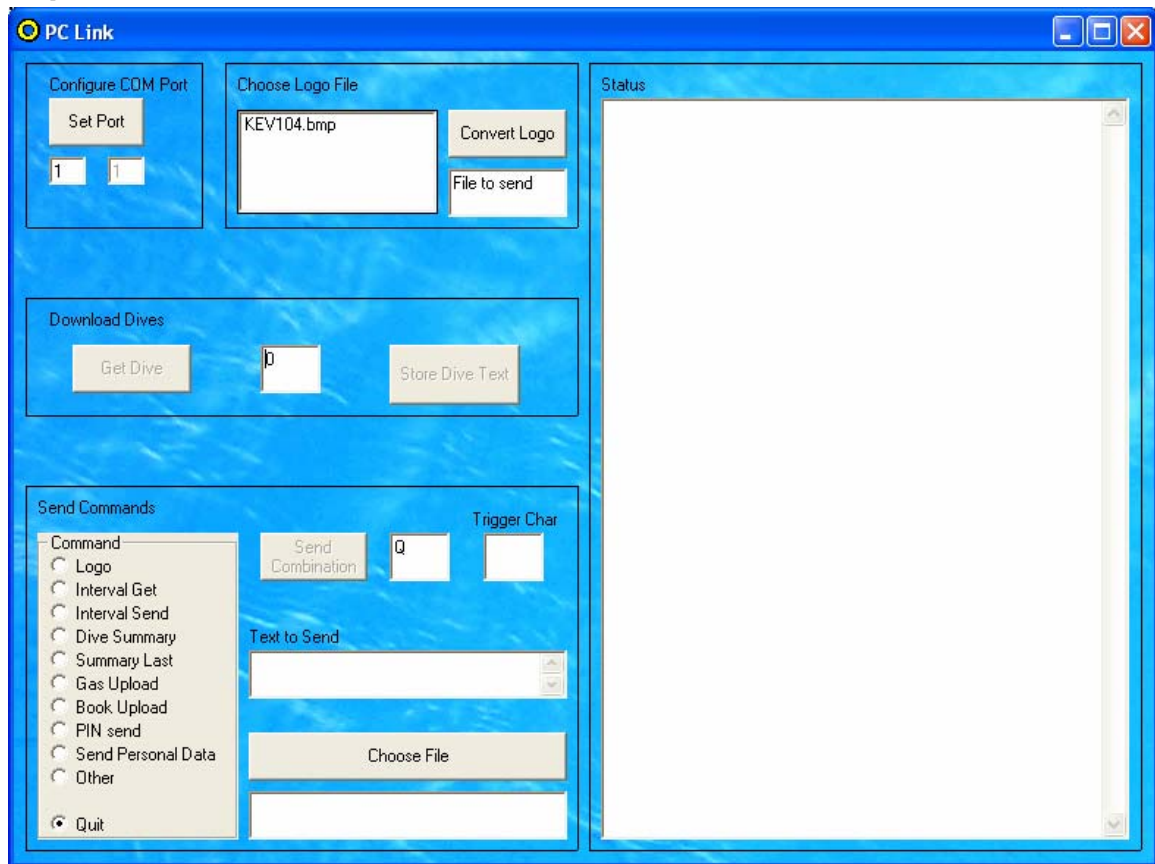

1. To import a dive from the Ouroboros, first put the Ouroboros into the PC link screen. This is under the [Options screen](#) menu items.
2. Connect the download cable from the Ouroboros to the PC serial port COM1.
3. Type in the correct COM port number into the COM port Text box. Click Open Com port.
4. Choose the import rebreather menu item on the PC software.
5. Then choose the dive number to download in the field next to Get Dive button. 0 corresponds to the most recent dive, 1 to the previous dive, and so on..
6. Check that there are a series of P letters appearing in the connection status window. If no letter Ps are showing, check the cabling, and that the Ouroboros is still in the PC link menu. It has a time out of the unit turn off period – 5 minutes or 50 minutes, depending on whether setpoint has been turned on or not. See [Main Dry Screen](#).
7. Click the Get Dive button on the PC Ouroboros software. The downloaded data appears in the status window.

8. When the download has finished, and Ps are displayed on the screen, the data can then be saved to a text file name. It is good practice to use a name that is relevant to the rig and dive location. The dive name is stored in the Location field when downloaded into the database system. Thus the dive can easily be recognized in the database if a good file name is used.
 - a. To automatically have these files put into the database, ensure that the files are saved in the default directory “new” that is a sub-directory off the installation directory of the software. Then when the [Download Dives](#) option is selected, the system prompts to automatically import into the database.

Download Dives

1. Automatic download importing into database

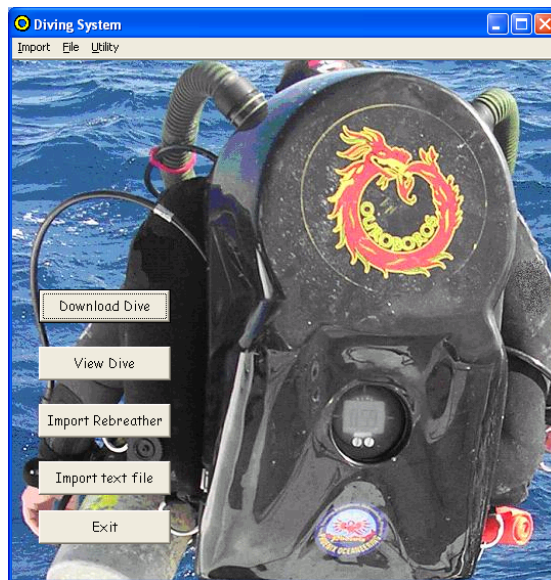

- a. From the main screen, use Download Dives option to import all new dives automatically into the database. This function imports all files in sub-directory “new”. The number of dives to download is shown, together with a continue, Yes, No option. Choose yes to download.

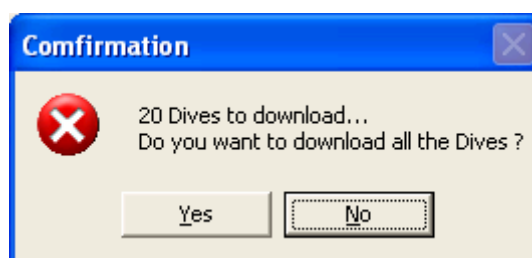

OUROBOROS

As the dives are being converted and downloaded into the database, the name of the current file being converted appears to the right of the Download Dives button.

When the dives have all been downloaded, a completed message box is shown. Click Ok to continue.



Import Text File

Manual importing of text files. If individual dives need to be imported, or chosen from a different directory, the Import Text file option from the main screen can be chosen.

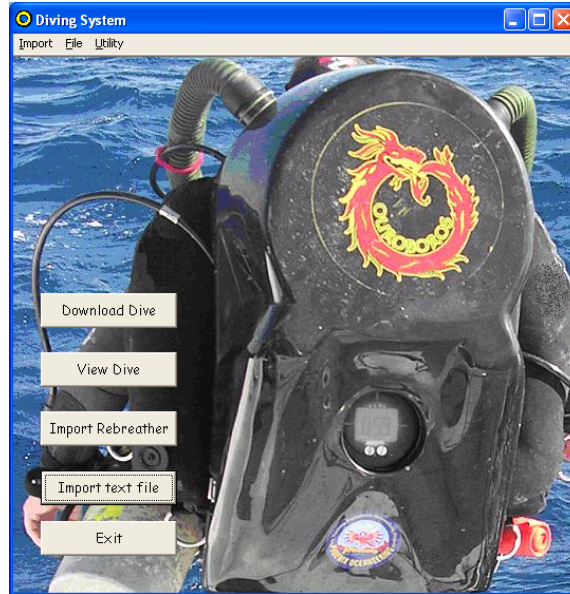

- b. After the data has been saved, the Import text file function is used to bring the data into the Ouroboros PC database.
 - i. Choose import Text file, and choose the file that had been saved in item 8 above.
 - ii. The conversion process takes approximately 2 minutes for a 90 minute dive on an average speed modern computer.
- c. If more dives are to be downloaded, repeat until all dives are downloaded and saved.

OUROBOROS

View Dives

Dives are viewed by first choosing a dive to view from the [Dive List](#). Then the dive information is shown on the [Main Dive Viewing Screen](#). Extra information can be entered into the

Dive List

1. Once the conversion has completed, the dive to view can be chosen from the View Dive option on the Ouroboros PC front screen.
2. From the next screen, which shows all the dives in the database, double click the dive number of the dive to be viewed.

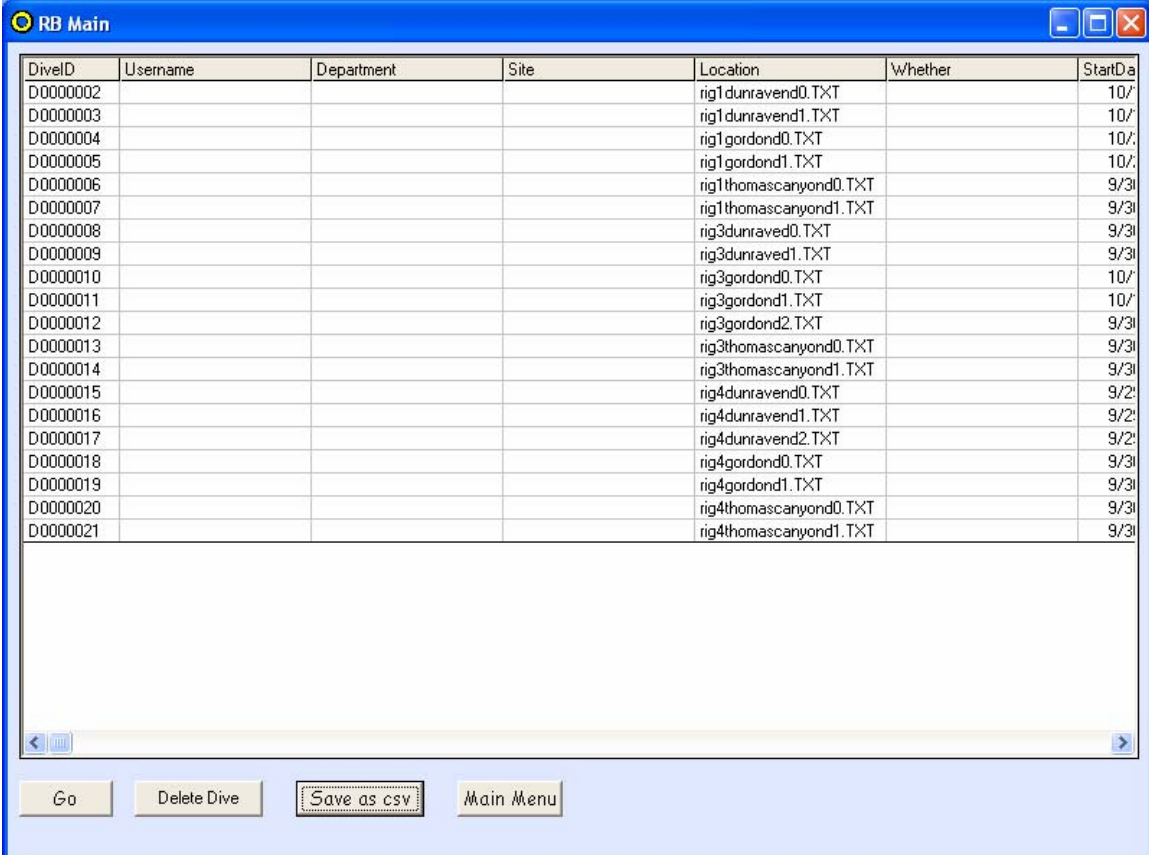

The screenshot shows a window titled "RB Main" with a table of dive data. The table has columns for DiveID, Username, Department, Site, Location, Whether, and StartDa. Below the table is a scroll bar and a row of buttons: Go, Delete Dive, Save as csv, and Main Menu.

DiveID	Username	Department	Site	Location	Whether	StartDa
D0000002				rig1dunravend0.TXT		10/
D0000003				rig1dunravend1.TXT		10/
D0000004				rig1gordond0.TXT		10/
D0000005				rig1gordond1.TXT		10/
D0000006				rig1thomascanyond0.TXT		9/3/
D0000007				rig1thomascanyond1.TXT		9/3/
D0000008				rig3dunravend0.TXT		9/3/
D0000009				rig3dunravend1.TXT		9/3/
D0000010				rig3gordond0.TXT		10/
D0000011				rig3gordond1.TXT		10/
D0000012				rig3gordond2.TXT		9/3/
D0000013				rig3thomascanyond0.TXT		9/3/
D0000014				rig3thomascanyond1.TXT		9/3/
D0000015				rig4dunravend0.TXT		9/2/
D0000016				rig4dunravend1.TXT		9/2/
D0000017				rig4dunravend2.TXT		9/2/
D0000018				rig4gordond0.TXT		9/3/
D0000019				rig4gordond1.TXT		9/3/
D0000020				rig4thomascanyond0.TXT		9/3/
D0000021				rig4thomascanyond1.TXT		9/3/

Main Dive Viewing Screen

1. The dive view screen shows the dive summary data, as well as the dive profile. The items plotted on the graph can be toggled on or off using the check boxes on the right of the window.

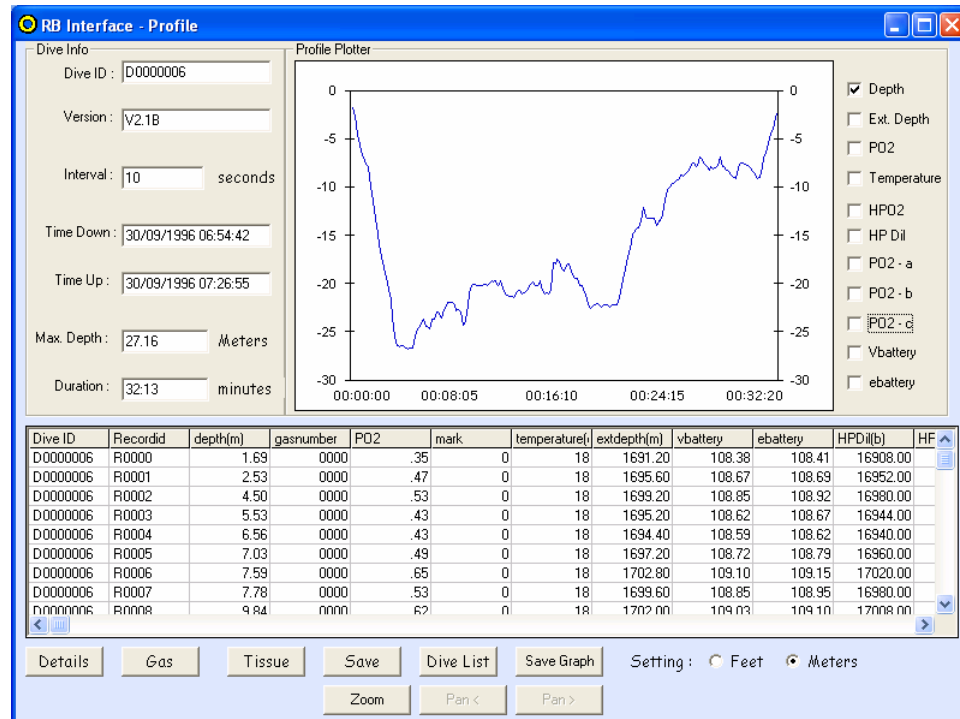

2. The summary dive information is shown on the top left area of the screen. These items include:
 - a. Dive ID number
 - b. Software version in rebreather at time of download
 - c. Record interval. This is used to determine the time between readings in the downloaded data. The value is downloaded from the rebreather. The value in the rebreather can be changed using the Interval Send command from the PCLink screen.
 - d. Time Down is the start time of the dive.
 - e. Time Up is the dive finish time
 - f. Max depth shows the maximum depth recorded during the dive.
 - g. Duration shows the duration of the dive in minutes and seconds.
3. The dive can be saved as a comma delimited file, for use in spreadsheets, by choosing the Save command at the bottom of the screen.

OUROBOROS

4. A snapshot of the screen can be saved as a bitmap using the Save Graph command
5. The Dive notes and summary details can be viewed and edited using the Details button. This opens the [Dive Details](#) screen.
6. The Gas list can be viewed by using the Gas button
7. The Tissue state after the dive can be viewed using the Tissue button.
8. Units can be toggled between feet and meters by clicking on the appropriate radio button at the bottom of the screen.
9. A point on the graph can be clicked. The corresponding data associated with this point is shown in the table below, together with data either side of the chosen point.

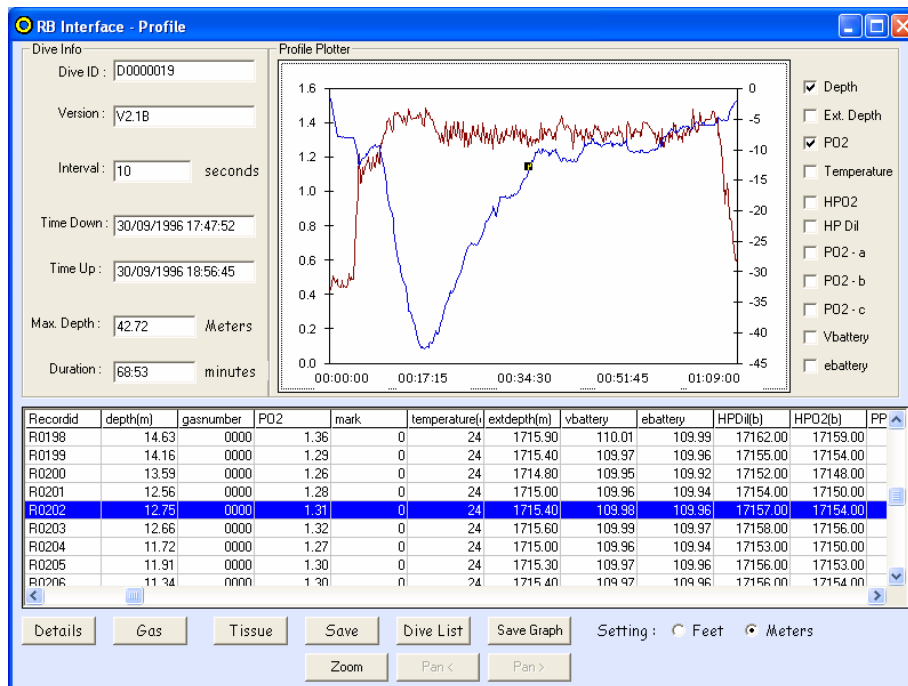

10. The graph can be zoomed by clicking the Zoom button. This toggles between 10 times Zoom and normal 1 times Zoom. When in 10 times zoom, the graph can be panned to the left and right using the Pan < and Pan > buttons.

Dive Details

RB Dive details

Dive Information

Dive ID : D0000005 Department :

Diver : Site :

Start Date : 10/21/1996 1:58:08 AM Location : rig1dunravend0.bt

Duration : 62:26 Weather :

Max. Depth : 41.98 Suit :

Buddy

Buddy :

Note

Dive Note :

Site Note :

Comments :

1. Some data fields are initially blank, as the information is for the diver to add in by hand as a logbook style entry. The location field is automatically filled in as the text file name that the dive data was saved to when connected to the rebreather.

OUROBOROS

Utility

This allows main system configuration items to be selected:

1. Units – Feet or meters are chosen under the Display Format pull down option. Units can also be chosen from the main Dive Display screen.

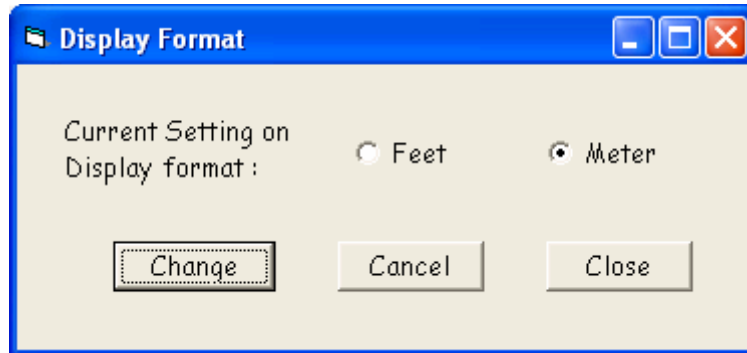

Maintenance

The Ouroboros rebreather has designed into it a 'no-tools' philosophy for field maintenance.

Items which can be field stripped/replaced are:

1. Hoses and hose end O-rings
2. The mouthpiece including the mushroom valves
3. The counter-lungs
4. The oxygen sensors
5. The Primary electronics batteries
6. The Backup display batteries
7. All primary O-rings
8. The manual gas bypass blocks

This means that all the main components of the unit can be cleaned and replaced as required without using any tools.

In addition, if major components have to be returned to the factory, the unit splits into two primary sections; the center section/Backup display and the electronics pod. The electronics pod can be separated from the case with a simple cross head screwdriver. Remove the harness and wing and the four screws are visible.

7. Remove the center section and disconnect the electrical connector between the center section and the electronics pod. The Backup display is permanently attached to the center section
8. Unscrew the regulator first stage caps
9. Remove the HP inlet whip to the regulator and the HP post
10. Undo the LP outlet
11. Lift out the regulator and hold the digital pressure sensor with the appropriate spanner while rotating the first stage.
12. Pass the HUD and Primary display through the case
13. Unscrew the four screws holding the electronics pod to the case
14. Lift out the pod, display and HUD

Storage

The unit should be stored harness up as this will allow moisture to drain away from the oxygen sensors. Ideal storage temperatures are between 5 and 20 degrees centigrade. Avoid direct sunlight or UV light or radiant heat exposure.

Electronics routine maintenance and assembly

1. Batteries –
 - a. **When any battery requires changing replace all the other batteries at the same time.** Battery types:
 - b. Backup battery - 3.6V AA lithium thionyl chloride

OUROBOROS

- i. Alarm RED LED will stay on whenever the unit is on. Normally the RED LED only comes on when the unit is about to turn off.
 - ii. Average life – 50 on hours. This is independent of diving or dry.
 - iii. Check polarity
 - iv. Check o-rings
 - c. Primary batteries – Alkaline C cell 1.5V
 - i. LOW Bat warning will appear on main Dry screen, Turn on screen and alarms screens. Change as soon as LOW battery first appears.
 - ii. Average life, depending on backlight usage – 50 on hours. This is independent of diving or dry.
 - iii. Check polarity
 - iv. Check o-rings
 - v. Put on top cover and screw locking ring down. There should be no thread visible under locking ring.
2. Backup
 - a. The Backup display is permanently attached to the center section.
 - b. Use top button to turn unit on. Backup will stay on for approx 20 seconds. Just before turn off, RED led will come on to show turn off is imminent
 - c. Red warning low battery LED on Backup – if it comes on as soon as unit switched on, the change batteries
 - d. Use second button to show mV instead of PO2. Change O2 cell if 7mV or less.
 - e. [Calibrate](#) O2 cells in oxygen. Undo the potentiometer covers on the rear of the Backup Display. Adjust each pot for each cell to read appropriate reading for gas being used – 1.00 for 100% O2 at 1 bar atmospheric pressure.
 - f. Refit pot covers. Ensure o-ring is in and thread closes squarely.
3. Primary
 - a. The Primary is permanently connected to the electronics pod.
 - b. Fit primary batteries unless already installed – see section 1
 - c. After a battery change if the rear facing display is blank you need to do a long press of both buttons to re-activate display.
4. You are now ready to do the [Pre-Dive](#) Checks

OUROBOROS

Component breakdown

Hoses

To remove a hose simply unscrew it from the mouthpiece or counterlung fitting. The inhale hoses ends have an opposite thread to the exhale hose ends to avoid connecting the loop around the wrong way around. To inspect the hose end O rings, push out the screw end securing clip and remove the screw end. Inspect, clean and re-grease with oxygen compatible grease.



Mouthpiece

If a leak is suspected in the mouthpiece assembly, remove the hose ends. With a blunt instrument, push past one of the mushroom valves to the edge ring of the opposite mushroom valve carrier.



DO NOT PUSH IN THE CENTRE OF THE MUSHROOM VALVE CARRIER, AS THIS WILL DAMAGE IT. Gently push until the carrier releases from the mouthpiece. Now remove the mouthpiece pin by unscrewing it. The pin nut will drop off on the inside of the mouthpiece.



Now the two inner barrel circlips can be removed from the inside.

Clean and LIGHTLY re-grease the outer of the barrel and the inside of the mouthpiece. Reassemble in reverse order. DO NOT PUSH ON THE INSIDE OF THE MUSHROOM VALVE CARRIER TO ASSEMBLE IT, USE

OUROBOROS

THE OUTER EDGE. This can be done by using a hose end with the O-rings removed.

Counter-lungs

The exhale counterlung (diver's right) is the one with the exhaust valve in it. This should not need maintenance. If it does, simply unscrew the valve top



being careful of the spring in side. Clean or replace the mushroom valve and reassemble the unit.

Oxygen sensors



See notes on calibration to test the oxygen sensors. If the cell readings appear erratic inspect the jackplug connection. Remove the sensors from the unit. Unscrew each jack plug. Clean the jackplug pin with warm soapy water or a soft instrument like a fingernail or piece of plastic. **DO NOT SCRATCH THE PIN.** Reassemble and check the readings.

Batteries

Battery alarms are displayed on the Primary display and the Backup display. **CHANGE ALL [BATTERIES](#) TOGETHER.** Ensure you put all batteries in the right way around.

HP Sensor accuracy check

A periodic check on the accuracy of the HP sensors should be carried out every 6 months. To do this, put a cylinder of known pressure into each of the cylinder high pressure connections. Check the HP readings against the expected value. If there is a discrepancy of greater than + or – 5 bar, contact the factory for recalibration services.

Primary O-rings

All O-rings in the center section, canister and hose ends can be easily removed and inspected. Look for damage and replace or clean as required. **PAY SPECIAL ATTENTION TO ALL THE CANISTER AND CANISTER TO CENTRE SECTION O RINGS.** Re-grease using oxygen compatible grease.

Manual gas bypass blocks

The central valve in the gas block can be removed by holding one end and unscrewing the knurled knob on the other end. The valve can then be



pushed out, be careful not to lose the return spring. Inspect and clean the O rings. On reassemble make sure all O-rings compress correctly into the shaft. Pressure tests the block.

Pipe work

The LP, filters, shut-off valves and pipework within the unit should not need maintenance other than at the factory service interval. If you suspect water ingress is contaminating and blocking the pipes or valves then the unit should be returned to factory.

Adjusting the ADV

The ADV is factory set and should not need adjusting. If you want to adjust the 'feel' of the ADV this must be initially done on the bench and then in the water.

1. Remove the Dome and Canister.
2. The ADV is located in the lower left section of the Center Section.
3. To decrease the breathing resistance, unscrew the cap with slot in it in $\frac{1}{4}$ turn increments.
4. Replace the Dome and with the diluent turned on evacuate the loop until the ADV triggers. Make further adjustments as required.
5. The ADV must now be tested in water as the hydrostatic affects of a diver rotating in the water may trigger the ADV when not required.
6. Enter the water wearing the unit and swim in all orientations ensuring the ADV does not trigger when not required.
7. **If you unscrew the ADV cap too much the Canister and Dome will not fit correctly. This is deliberately designed this way to ensure safe operation of the ADV.**



OUROBOROS

ADV- leak testing and cleaning

If you suspect the ADV is bypassing gas then it may need cleaning.

15. Remove the Dome and Canister.
16. Open the diluent valve and ensure the ADV shut-off is open.
17. Remove the two screws holding the ADV cover plate and take out the spring and spring carrier.
18. Listen for gas seeping from the valve or apply soapy water to the valve and look for bubbles.
19. If it is leaking, shutoff the diluent cylinder and purge the gas lines.
20. Unscrew the pilot valve at the tip of the ADV.
21. Immerse in white vinegar or a suitable cleaning fluid, preferably within an ultrasonic cleaner.
22. Reconnect the valve and pressurize the line again looking for leaks.
23. Reassemble the unit making sure the narrow slot on the spring carrier is located on the shaft of the valve.



If leaks persist contact your nearest service center.

O-Ring care

The O-rings in the unit are specifically designed for use in the Ouroboros rebreather and must not be replaced with non-standard items.

All O-rings should be regularly inspected and cleaned. Particular attention must be given to the main dome and CO2 canister O-rings which should be checked prior to every dive. O-rings can be de-greased and cleaned in warm soapy water and then rinsed in fresh water and dried before re-greasing.

Only oxygen compatible greases should be used with the rebreather's O rings.
Recommended greases are Fomblin RT15, Halocarbon 25-5S or Oxygen.

Oxygen sensor care

Post dive, the oxygen sensors can be removed from the rebreather in a group or individually and kept in a warm dry place before using again. Basic care includes;

1. Never store sensors for long periods before use.
2. Never subject sensors to high temperatures i.e. (Car rear shelf).
3. Never freeze sensors (left in cars overnight).
4. Never subject sensors to physical shocks.
5. Never subject sensors to vacuum.
6. Never submerge sensors in liquids.
7. Never attempt to open a sensor.
8. Sensors deteriorate very slowly and near the end of their useful life may show a drift soon after calibration. Sensors should be checked periodically in 100% Oxygen.

Water and corrosion on the sensor jack plug may give false PO₂ readings. Seawater may dry leaving a deposit on the jack connectors and the sensor membrane. Always leave the sensor jack locking ring finger tight on the sensor socket. If you suspect corrosion, unscrew the jack plugs from the sensors and clean the plug on the end of the cable with a cloth and/or white vinegar.

Check the sensor membrane. A certain amount of moisture will always appear on and around the sensors. If you suspect excessive water has made contact with the sensor faces, rinse with fresh water. Remove excess water carefully with a paper tissue and leave to dry in a warm area. If the jack socket on the sensor is wet the sensor may be damaged as the electronics inside the sensor will also be wet. Wash out with fresh water and leave to dry out in a warm area. If all the salt is removed corrosion may be prevented.

Upon reassembly, check the calibration of the sensors before diving.

OUROBOROS

Disinfecting

To avoid the chance of infection, as a minimum the breathing hoses and mouthpiece should be cleaned with fresh water after a dive.

The recommended disinfectant product for the Ouroboros is Virkon®.

The use of any other disinfectant may damage the component parts of the rebreather.

Any disinfectant used must be;

- Virucidal
- Fungicidal
- Bactericidal
- Tuberculocidal
- Fast acting
- Biodegradable

Items to be disinfected are;

- The mouthpiece and hoses
- The counter-lungs
- The center section
- The dome
- The canister

Basic disinfecting can be conducted by making up a solution in the correct quantities and soaking or wiping the part with the solution. Rinsing instructions are included with the Virkon® handling instructions.

The mixing ration for Virkon® is one 50g sachet will make 5 liters of disinfecting solution. Parts should be soaked for between 5 and 10 minutes. Tap water is a suitable temperature for use with the solution. Do not use with water above 50 degrees centigrade.

Please make sure you read the safety information on Virkon® before using, this can be found at http://www.day-impex.co.uk/virkon_powder.pdf.

The counterlungs and breathing hoses can be disinfected in situ. To do this remove the dome and canister. Remove the O2 sensors. Now with the mouthpiece closed, pore the solution into the two counterlung holes in the center section. Move the solution around the rebreather and leave for 5-10 minutes. Now drain it out and flush through with clean water. Remove hoses and allow to dry.

CO2 absorbent storage

Once a CO2 canister has been packed it should remain so. Do not attempt to remove absorbent from a part used canister and dry, refurbish or re-pack the absorbent in any way.

After a dive and providing the absorbent canister remains in a sealed state (i.e. within a closed rebreather loop) it may be used again until the limit of the absorbent timer is reached. Storage for more than 24 hours is not recommended and used absorbent or absorbent removed from the canister should be discarded.

Handling Absorbent

CO2 absorbent may cause burns to eyes and skin. First aid treatment is as follows;

- | | |
|---------------|--|
| 1. Inhalation | Remove from exposure. Seek medical attention. |
| 2. Skin | Drench with clean water and seek medical attention if skin becomes inflamed. |
| 3. Eyes | Irrigate thoroughly with clean water. Seek medical attention. |
| 4. Ingestion | Wash out mouth thoroughly. Seek medical attention. |

Always fill canisters in a well-ventilated environment . Avoid contact with eyes and skin.

Repairing counterlungs

In the unlikely event of major counter-lung damage will require a to return factory for repair, especially if a seam becomes damaged. However, small 'pin prick' damage can be 'patch' repaired.

Closed Circuit Research Ltd supply an optional repair kit. To use this first wash the counterlung in warm, soapy water and rinse with fresh water. Allow to fully dry.

The patch is applied with pressure. The best way to do this is to apply the patch and then 'sandwich' the counter-lung between two pieces of wood in a vice or clamp. Leave for ten minutes and then [pressure test](#) the counter-lung.

OUROBOROS

Appendix 1 - Safety Design Criteria

Functional Safety as set out in IEC 61508 and related safety issues have been of particular importance in designing the Ouroboros rebreather. Of particular relevance has been the considerable diver input on types of failure and user error within rebreather systems, both in the mechanical and control systems. From this direct hands on information, safety systems within the Ouroboros are higher than on any other current rebreather. On top of this, safety design has been the driving force behind the Ouroboros, to be as forgiving as possible to diver error, and to component failures. From this point of view, this section includes safety considerations that the manufacturers have employed to provide the safest, most intuitive and user-friendly rebreather currently commercially available.

The safety concept of the Ouroboros rebreather is to ensure that no single failure of electrical or electronic or programmable electronic device or system will cause failure of the complete system.

From this concept and scope definition, the following hazards and associated risks have been analysed. The manufacturer's analysis has highlighted the following areas where the electronic and software systems affect the operation of the system:

Item	Description
1	Solenoid valve operation
2	PO2 sensor operation
3	Main electronics hardware
4	Main electronics software
5	Primary Display
6	Cable interconnect systems
7	Batteries

These items have been analysed with particular relevance to known rebreather failure scenarios listed below:

Item	Description
1	O2 addition valve stays open causing extremely high PPO2. This causes diver to convulse.
2	No O2 addition due to valve failed shut. This causes gradual reduction in PPO2, and eventually blackout.
3	HP O2 not turned on
4	HP diluent not turned on
5	CO2 canister stack time exceeded
6	Battery Failure
7	Cable breakage
8	Electronics flooding

From this, the following table of failure and error scenarios summarises the analysis.

OUROBOROS

Table of Safety and Functionality safety failure modes

Item	Part	Function	Failure Mode	Solution
1.1	Solenoid valve	Add O ₂ to breathing loop	Jammed open by dirt in HP gas	HP O ₂ high flow rate. General Alarm advised to diver on HUD, vibration motor and primary display. The rear O ₂ display/advises a buddy of alarm and PO ₂ . Diver can then manually turn off gas using O ₂ isolation valve.
1.2	Solenoid valve	Add O ₂ to breathing loop	Jammed closed by mechanical failure	Reduction in PO ₂ cell readings. PO ₂ Alarm advised to diver on HUD, vibration motor and primary display. Diver can then manually add O ₂ using manual O ₂ addition valve. The rear O ₂ display/advises a buddy of alarm and PO ₂ .
1.3	Solenoid valve	Add O ₂ to breathing loop	Software error causes software to continually add oxygen.	Electronic hardware uses charged capacitor to fire valve. This charging is interlocked so that when firing, the charging circuit is removed. Therefore the valve can only fire electrically for a maximum of 2 seconds.
1.4	Solenoid valve	Add O ₂ to breathing loop	Water ingress/flooding of main electronics.	Electronic hardware uses charged capacitor to fire valve. This charging is interlocked so that when firing, the charging circuit is removed. Therefore the valve can only fire electrically for a maximum of 2 seconds.
1.5	Solenoid valve	Add O ₂ to breathing loop	Cable failure	Electronic system monitors a feedback signal from the solenoid. In case of cable break, electronic circuit will detect failure to receive the signal. Valve Alarm advised to diver on HUD, vibration motor and primary display. The rear O ₂ display/advises a buddy of alarm and PO ₂ .
2.1	Main electronics	Software and hardware to operate automatic oxygen addition, decompression software and user control interface	Software crash	Watchdog system will restart electronics. Default operation values suitable for basic operation. HUD and primary display functions will be lost while unit reboots. Diver should use Backup display device. However, diver should abort dive, using Backup display for po ₂ information. Auto O ₂ addition should be turned off using isolation valve. Manual addition of O ₂ should be used.

OUROBOROS

Item	Part	Function	Failure Mode	Solution
3.1	Primary display	User interface for viewing and inputting data.	Cable break, Primary display flooded.	Water ingress inhibited from entering main electronics by potted cable junction box at bottom of main electronics. HUD continues to give diver PO2, Decompression, Valve fire and general alarm information. Backup display continues to give PO2 readings.
4.1	HUD	4 LED user interface to view status of:PO2, Decompression, Valve fire and general alarm	Cable break	Primary display continues to operate independently of HUD. All lines are buffered and cannot cause failure of overall system in either short circuit or open circuit failure scenarios. The rear O2 display/advises a buddy of alarm and PO2.
5.1	Main Battery	Supplies power to valve control system and Main electronics software circuit board.	Failure of main battery	Before failure, low battery warning on HUD and primary display will be shown. On main battery failure, the HUD and main electronics software system will continue to operate. However, the valve will not fire. Low Battery Alarm advised to diver on HUD, vibration motor and primary display. The rear O2 display/advises a buddy of alarm and PO2. The system should then be controlled using the manual O2 addition valve. The Backup display should be used to check primary display readings are still correct.
6.1	Backup Battery	Supplies power to Main electronics software circuit board if main battery fails.	Failure of backup battery	If Main battery is operational, then all systems will continue. If main battery also failed, then main system will fail completely. Backup system will continue to operate as it has a further independent battery.
7.1	PO2 cells	3 oxygen po2 cells provide oxygen partial pressure signal to main electronics and Backup electronics	Failure of single cell	Software logic disables any single cell that is out of range compared to the readings of the other two. Backup display shows all readings. Backup display also shows mV reading to check actual level independently of calibration factors. Bad cell Alarm advised to diver on HUD, vibration motor and primary display. Backup system is passively fed from PO2 cells. Failure of buffering electronics to main electronics will not disable Backup display readings.

OUROBOROS

Item	Part	Function	Failure Mode	Solution
7.2	PO2 cells	3 oxygen po2 cells provide oxygen partial pressure signal to main electronics and Backup electronics	Failure of two cells	Software logic disables any cells below or above operational range. Backup display shows all readings. Backup display also shows mV reading to check actual level independently of calibration factors. Feature in diving screen allows diluent flush PO2 level check to determine which cells are following correct reading of diluent PO2 at current depth. Bad cell Alarm advised to diver on HUD, vibration motor and primary display.
7.3	PO2 cells	3 oxygen po2 cells provide oxygen partial pressure signal to main electronics and Backup electronics	Failure of three cells	Primary and Backup systems will fail to show correct PO2. However, an option of a fourth cell allows a further independent PO2 measuring device to be used.
7.4	PO2 buffering pcb	Amplifies PO2 cell reading to send to Main electronics. Resistor only passive buffer for cells to Backup	Failure of electronic circuitry, or cable breakage from center section to main electronics	Bad cell Alarm advised to diver on HUD, vibration motor and primary display. Backup system is passively fed from PO2 cells. Backup display will continue to operate. Failure of buffering electronics to main electronics will not disable Backup display readings.
8.1	Backup display	Provides calibrated PO2 display and raw mV display	Failure of electronic circuitry, or cable breakage from center section to Backup display	Backup display will fail. Main electronics system will continue to operate and show PO2. PO2 cells are buffered before leaving the center section, so that any cable failure, either open circuit or short circuit will not cause failure of other parts of the system.
9.1	High pressure O2	High pressure O2 cylinder sensor	HP O2 not turned on	Low O2 HP warning. Low HP Alarm advised to diver on HUD, vibration motor and primary display.
9.2	High pressure Diluent	High pressure Diluent cylinder sensor	HP Diluent not turned on	Low Diluent HP warning. Low HP Alarm advised to diver on HUD, vibration motor and primary display.
9.3	High pressure O2	High pressure O2 cylinder sensor	HP hose failure	Low HP warning or high usage rate. HP Alarm advised to diver on HUD, vibration motor and primary display.
9.4	High pressure O2	High pressure Diluent cylinder sensor	HP hose failure	Low HP warning or high usage rate. HP Alarm advised to diver on HUD, vibration motor and primary display.
10.1	CO2 canister stack time	Absorbs CO2 from exhaled gas	Usage time exceeded	Software timer alarm – Canister duration Alarm advised to diver on HUD, vibration motor and primary display.

OUROBOROS

Item	Part	Function	Failure Mode	Solution
11.1	Rear O2 display and Alarms indicator	Displays PO2 and 4 Alarm LEDs to buddy	Primary and Hud systems fail, or diver does not act on alarm	The rear O2 and Alarm display gives information to the divers buddy on correct system operation. The buddy can see PO2 and Alarms, so can check on the diver should any problem be spotted by the buddy rather than the diver.
12.1	Complete System	Run rebreather	User forgets to turn unit on before diving	Wet contact automatically turns unit on when entering water
12.2	Complete System	Run rebreather	User forgets to turn unit on before going in chamber	Depth sensor checks current external pressure every minute. If the pressure is above 1.6 bar, the unit will turn on automatically.

From the analysis, there is only a single control function that the software performs:

- **Fire solenoid when the PO2 is below the required setpoint**

All other tasks are subordinate to this, and essentially do not directly perform functions absolutely necessary to the rebreather.

From a user perspective however, there is desire to have increased functionality, for example, to control the set point during the dive and prior to diving.

Also from an ease of use point of view, other functions such as decompression algorithm, dive profile downloading etc.. have been incorporated into the software design.

Safety information has been added to the Ouroboros rebreather, by monitoring other external parameters, and building software and hardware systems that give as much clear information to the diver that the rest of the support hardware such as high pressure cylinders, are operating correctly. The incorporation of automatic devices run by the software to say turn on the high-pressure cylinder if the user forgets to, could be incorporated. However, this would create a level of complexity and price far above that currently expected by divers, and instead are promoting the ethos – Keep It Simple.

Therefore, although functional safety system interlocks in the purist interpretation of the ISO standard could be far more extensive, the manufacturers at this stage have used the sensor information and software analysis to alert the diver, rather than directly control devices and systems in the rebreather. This is considered a safer approach than over complicated expensive failure interlocks that could themselves cause dangerous scenarios in case of failure.

Appendix 2 –Programmable Systems

The programmable systems in the Ouroboros rebreather have been developed with reference to the management control and product design requirements of ISO technical reference documents – ISO/IEC 12207 and IEC 60300-3-6/60300-2.

The in-house procedures have taken the programmable systems design and overall product design to levels of user performance, maintainability and reliability never previously available in a rebreather product.

Furthermore, coupled with the mechanical aspects of the rebreather system design, the Ouroboros can be operated independently of the electronics and software system in the event of catastrophic failure of the main electronics control system.

From an overall design perspective, the Ouroboros has used the Dependability design issues of the ISO standards in all aspects of the product design, including mechanical, electronic hardware and software.

The Dependability programme has ensured that revisions to software and associated electronics systems have been developed in a controlled loop of planning, design, implementation and testing.

At each software level stage, extensive testing involving bench testing, user dry testing and finally diver trials are conducted to ensure a quality level commensurate with the needs of divers.

The design and testing are conducted within a management framework that provides direct control over the software and product development process. This ensures that requirements and specification changes are understood by all parties, and tested extensively by the software and diver development teams before being put into a release for third party divers.

The software, hardware and mechanical systems have been developed using a small team of highly experienced staff. Manufacturing and prototyping tasks have been sub-contracted out to third party specialized manufacturers. Critical parts such as PCB assembly are subcontracted to firms with ISO9000 QA certification. Off the shelf parts are supplied by ISO9000 certified companies. The Ouroboros Manufacturer is currently undergoing ISO9000 certification.

Key to the Ouroboros development has been testing and design feedback, to develop the requirements beyond that of the original design criteria. Unlike many current software projects in the IT domain, the Ouroboros specification was not fully realised until testing and development of new ideas had been carried out. Diver input from use of previously existing product defined some of the improvements that would be important to a new design. However, testing and then further refinements of these ideas were developed over a period of time. Thus the full specification has grown with the product design

OUROBOROS

implementation, and this had been managed within a Dependability Programme.

Appendix 3 - Shipping

The Ouroboros requires an export license if shipped out of the country of use whether new or second hand.

There is an exception to this for personal use detailed in DTI guidance Section 8A 002q, which allows the export for personal use when accompanied by the user. For the latest information on this contact <http://www.dti.gov.uk/export.control/>

Individual countries will have their own export requirements and it is up to the user to investigate these.

OUROBOROS

Software Implementation

The processes within the software architecture of the Ouroboros have been summarized in the diagram below:

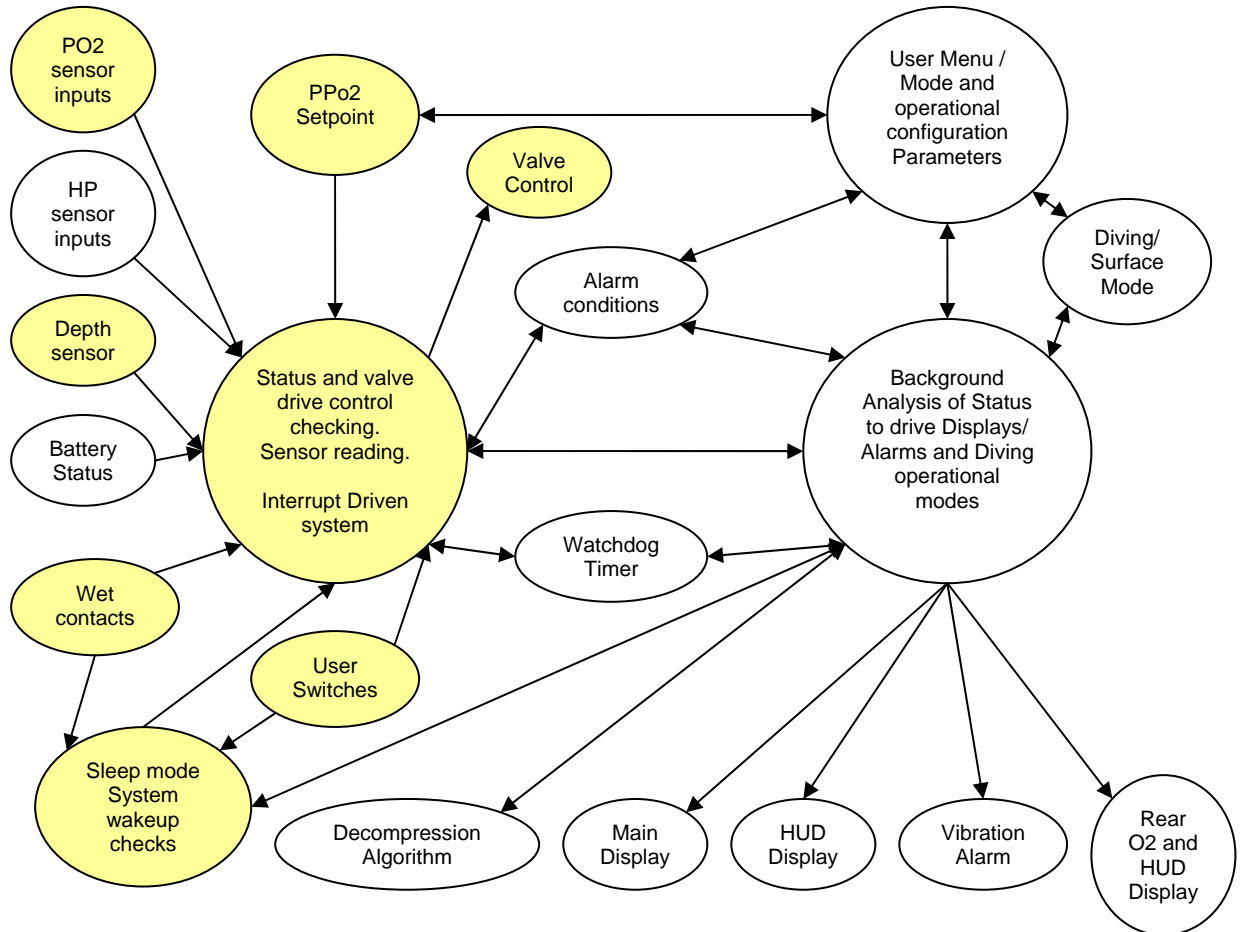

OUROBOROS

Software Processes

The items in yellow are given the highest priority in software to ensure the unit is on and able to drive the solenoid valve, independently of other menu and user operation functions. In accordance with the dependability programme, the software systems have been developed to maintain operational separation of the control and status systems from the background tasks. Main control systems such as valve firing are achieved using an interrupt based timing system. Below is an interrupt priority table, showing some of the main tasks with the highest priority tasks at the top.

Priority	Tasks
1	Valve Firing, Status checking, Alarm driving
2	Analog to digital input conversion
3	Action changes from user
4	Display updates
5	Decompression Algorithm update
6	Telemetry functions

The operation of these functions has undergone significant bench testing. Over 10,000 hours bench test time has been performed testing overall reliability, functionality and endurance. At each stage this has been followed up with extensive dry user trials, testing the functionality and robustness of the software systems to different user knowledge and operating idiosyncrasies. This has then been followed up with underwater trials, incorporating divers with different knowledge and operational requirements. Feedback from these tests has then gone into design reviews. These are then implemented, and the trialing and testing processes repeated.

Further unmanned chamber trials have been performed to optimise system operations in a controlled environment, to ensure and improve all functionality of the system, including software control systems.

These reviews are also analysed using FMECA, resulting in a rigorous analysis and design review specification.

Coupled with this, the core of the main electronics processing is achieved using the software and hardware used in the Delta P VR3 dive computer, which has over 4000 users and over 500,000 accumulated dive hours performed using it.

Vision Test

Your eyesight must be checked before using the Ouroboros rebreather.

Wearing your normal diving mask can you read all the characters from 40cm (16 inches) away.

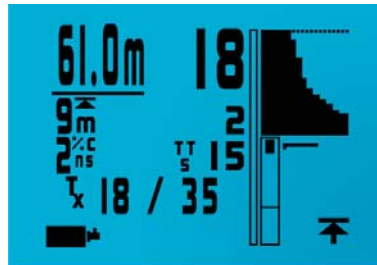

OUROBOROS

Glossary of Terms

Term	Description
HP	High Pressure gas circuit (232 bar)
O ₂	Oxygen
CO ₂	Carbon Dioxide
He	Helium
Dil	Diluent – Gas used to dilute oxygen in breathing loop
Canister	The container for the CO ₂ absorbent
Center Section	The base plate to which the counterlungs attach and which houses the Oxygen sensors
Gas block	The unit which manually bypasses the automatic gas addition system and provides an input for external gases
Dome	The cover which houses the canister and attached to the center section
LP circuit	The low pressure (10 bar) gas circuit
Isolator	The ADV and solenoid gas shut-offs
ADV	Automatic diluent addition valve
Solenoid	The oxygen solenoid
PPO ₂ / PO ₂ / PP	Partial Pressure of Oxygen
OTU	Oxygen Toxicity Unit
MOD	Maximum Operating Depth
M	Meters
Ft	Feet
mV	Milli-volt
V	Volt
HUD	Heads Up Display
Bar	Measurement of Pressure in SI units
mBar	Milli-bar
PSI	Measurement of Pressure in imperial units Pounds per square inch
LED	Light Emitting Diode – semiconductor device that gives out light. Can be different colours. Very reliable compared to light bulbs.
LCD	Liquid Crystal display
IC	Integrated circuit
VLSI	Very Large Scale integration – used to describe very large ICs.
PIN	Personal Identification Number

Warranty

The Ouroboros is warranted for the first owner for 24 months from date of purchase

Conditions:

All warranty work must be authorised by Closed Circuit Research Ltd. Before returning the apparatus for any reason, please telephone the factory for advice. If it is deemed a factory repair is required the apparatus should be returned, postage and insurance paid, with a copy of the purchase receipt, directly to the factory or dealer.

1. Misuse, neglect or alteration renders all warranties null and void.
2. The use of non Closed Circuit Research Ltd. approved accessories is not recommended and may invalidate your warranty.
3. This warranty is not transferable.

Your statutory rights are unaffected.

Exclusions

1. The batteries are not covered by the warranty.
2. The oxygen sensors are not covered by the warranty, they will need to be replaced every 12-18 months or sooner depending on the ppO₂ they are stored in and the hours of use
3. The counter-lungs are not covered against puncture.
4. Disinfecting with anything than the recommended disinfectant in the recommended dosages may damage the unit.

All products are sold only on the understanding that only English Law applies in cases of warranty claims and product liability, regardless of where the equipment is purchased or where used.

OUROBOROS

Ouroboros Rebreather General Specification

The following is the provisional specification for our pre-production prototype. This is subject to change without prior notice. This is a fully functional prototype which is current in its field trial cycle.

General

Maximum tested depths (breathing).	40m, air diluent. 100m Heliox 9/91.
Maximum tested depth (housings).	130m as per EN14143.
Recommended absorbent.	Sofnalime 797 grade.
Year of Manufacture.	2005.
Manufactured standard.	EN14143
Operating temperature range.	+4 degrees to + 32 degrees centigrade.
Short term air storage (hours)	-10 degrees to +50 degrees centigrade.
Long term air storage (days)	+5 degrees to +20 degrees centigrade.

1. Breathing loop

- a. Canister
 - i. Size options:
 - Type A. 2.7kg/5.9lb. Duration = 2.5 hours to 0.5% CO₂. 40m. 40l/min @1.6l/min CO₂. 4 Degrees C.
- b. Counter lung
 - i. Volume Approximately 5.5l
 - ii. Rear mount split lung configuration
 - iii. Material Nylon coated polyurethane
- c. Gas injection
 - i. O₂ Automatic – solenoid valve
 - ii. O₂ manual – over shoulder injection block with additional external O₂ cylinder input capability with isolator.
 - iii. Diluent Automatic addition
 - iv. Diluent Manual addition – over shoulder injection block, with additional external diluent input capability. Version 2 with isolator.
- d. Water dump – automatic dump valve
- e. Over pressure – automatic dump valve
- f. Hoses High impact resistant, crush proof nylon coated rubber

2. High pressure

- a. Diluent cylinder – capacity 2 liters, 232 Bar, 15cuft, 3400PSI
- b. O₂ cylinder – capacity 2 liters, 232 Bar, 15cuft, 3400PSI
 - i. Other sizes can be fitted
- c. DIN fitting
- d. Internal small bore 3mm, 1/8” stainless high pressure piping
- e. 20micron oxygen filter to protect solenoid and ADV from debris ingress

OUROBOROS

- f. External Stainless steel armored hose for cylinder DIN connection
- g. Solid state digital electronic high pressure sensors to feed content and usage rate information to main electronics

3. Electronics Control and display system

- a. Central canister
 - i. 3x po2 cell pre-processor board in central canister
 - Nominal 10mV O2 sensor
 - Passive split to Backup/Main electronics
 - Active amplification of feed to main electronics
 - ii. 4th cell to feed independent backup PO2 and decompression device – eg VR3
- b. Primary Display – full control and detailed system setup
 - i. Diluent setup
 - ii. PO2 setpoint setup
 - iii. Alarms setup
 - iv. Log book
 - v. Gas profiles
 - vi. Dive plan
 - vii. Open circuit bailout
 - viii. Simulate
 - ix. PC link
 - x. High pressure – O2 and diluent displays
 - xi. Sensor calibration and ON/OFF/Auto select of individual sensors or all
 - xii. Summary of system values and alarm status
 - xiii. Decompression requirements
 - xiv. Game
 - xv. Calendar
 - xvi. Altitude/Atmospheric pressure
 - xvii. Main dive screen – depth, time, Total time to surface, PPO2, Setpoint, Deco graph,
 - xviii. In water dive profile
 - xix. Backlight
- c. Head Up Display HUD
 - i. PO2 - Green LED
 - Steady = PO2 on setpoint
 - Slow flash = PO2 just Below setpoint
 - Fast flash = Very high or very low (<0.16 and >1.6)
 - ii. Deco Stop - RED LED
 - Steady = At deco stop
 - Slow flash = Deco stop required, but much too deep
 - Fast flash = too shallow
 - iii. Valve – Blue LED
 - Single flash = Valve operation OK
 - Rapid flash = Valve electrical feedback not received – Valve malfunction

OUROBOROS

- iv. General Alarm – White LED
 - Steady = No General alarms, system OK
 - Slow flash = HP content alarm
 - Medium Flash = Battery alarm
 - Fast flash = HP rate alarm
- d. Backup display system
 - i. Shares PO2 cells in central canister
 - ii. Provides total software independent voltmeter and normalized PO2 readings on LCD digital voltmeter for individual oxygen cells
 - iii. Backlights
 - iv. Independent battery – AA cell
 - v. Lithium Thionyl Chloride battery preferred – approx 40hrs continuous operation
 - vi. 10 second on timer to conserve battery
 - vii. Low battery warning LED
- e. Main electronics
 - i. Battery – computer system
 - single C cell
 - Approx 40 hrs continuous use on Alkaline C style battery
 - Lithium Thionyl Chloride Cell 3.6v can be fitted for extended duration
 - ii. Battery – valve system and backlights
 - 2x C cell
 - Approx 2000x 1second firings of solenoid valve – equivalent to approx 40 hours diving
 - iii. Power sharing available in the event of a cell failure
 - iii. Valve drive – proof against single component failure causing solenoid valve continuous operation. Valve failsafe normally closed and in-line valve filtration fitted.
 - iv. 16 bit Microprocessor control system
 - v. Damage to any single external cables will not cause catastrophic failure of main electronics
 - vi. DC to DC converter system to extract maximum performance from batteries
- f. Integrated depth sensor
- g. Turn on mechanism:
 - i. Primary display reed switch
 - ii. Wet contact turn on
 - iii. Depth reading > 1.5metres measured on depth sensor
 - iv. Manual dive mode for chamber and saturation bell usage
- h. External stainless steel diaphragm depth sensor option for chamber use.
- i. In system re-programmability
- j. Connection to main canister PO2 sensor
- k. Full data downloading of all system parameters and data logged information
- l. Data record rates are user settable with a minimum resolution of 1 second.

m.

4. Solenoid Valve

- a. 1.5 watt, 12 volt
- b. 15bar+ rated

5. Mechanics

- a. 4 point harness system
- b. Integral weight system
- c. Integral BCD
- d. Carbon fiber Kevlar backplate system

6. Breathing performance

The rebreather meets EN14143 in all of the breathing performance test criteria with the exception of the pitch +180 degrees/roll 0 degrees (diver on back) where it is 5.39mb outside the standard and the pitch 0 degrees/roll + 90 degrees (diver on one side) where it is 2.24 mb outside the standard.

This is to be expected of a back mounted counterlung design and can be compensated for by the diver by adjusting the loop volume.

This rebreather has been tested to a maximum of 100m with a Heliox diluent as per EN14143.

The pressure housings have been tested to 130m as per EN14143. While the rebreather may continue to function and provide depth/time, PO₂ and decompression information past this depth, the structural integrity cannot be guaranteed.

Use outside of these parameters increases risk of personal injury.

OUROBOROS

Index

- addition of oxygen, 64, 66
- alarms**, 32, 36, 42, 54, 57, 61, 64, 81, 100, 122
- Alarms, 32, 76, 81, 85, 121
- assembly, 99
- Atmospheric, 44, 50, 61, 83, 121

- backlight, 78, 79, 83, 100
- bailout**, 47, 70, 74, 121
- Battery, 32, 44, 61, 62, 77, 81, 82, 83, 99, 122
- Breathing performance, 68
- Breathing Performance and Pathways, 68

- Calibration, 49, 50
- canister, 68, 69, 70, 71, 121, 122
- canisters, 65, 71
- closed circuit rebreather
 - components, 66
- COM port, 90
- conversion, 93, 94
- counter lung, 68, 69

- decompression, 32, 38, 42, 45, 46, 47, 48, 49, 52, 53, 64, 65, 66, 75, 81, 121
- Decompression, 32, 64, 79, 80, 81, 121
- Decompression algorithm, 64
- diluent**, 47
- Diluent, 45, 55, 66, 68, 83, 120, 121
- Dive Details, 96, 97, 115
- Dive List, 94
- Dive notes, 96
- dive view screen, 95
- download**, 65, 71, 75, 77, 83, 90, 91
- Download Dives, 89, 91, 92
- downloaded data, 90
- Downloading, 88
- duration, 62, 65, 68, 69, 71, 122
- Dvo, 34, 36, 42, 52, 53

- electronic, 63, 66, 67, 69, 70, 74, 78, 121
- electronics, 65, 66, 68, 74, 75, 76, 77, 78, 82, 85, 87, 121, 122
- Electronics, 74, 76, 83, 85, 99, 121
- Enabled Diluent, 47

- Failsafe, 85
- failure, 48, 50, 63, 65, 68, 75, 77, 78, 82, 85, 122
- FLAGS, 32, 35, 44, 81

- Gas Adjust, 34, 46, 47, 50
- Gas list, 96
- Gas Select Screen, 46
- General Specification, 108, 113, 118, 120

- Head Up Display, 75, 78, 79, 121
- high pressure, 55, 69, 120, 121
- High-pressure**, 66, 78
- History, 63
- HP, 32, 34, 36, 42, 54, 55, 61, 62, 73, 75, 81, 122
- HUD, 32, 52, 53, 75, 78, 79, 80, 81, 85, 121

- Import, 90, 93
- Import Rebreather, 89, 90
- Import Text File, 89, 93
- Installation, 88

- Log, 89, 121
- Logging, 79

- Main Dive Screen, 38
- Main Dive Screen-Saver, 43
- Main Dive Viewing Screen, 94, 95
- Main Dry Screen, 35
- Main Dry Screen-Saver, 37
- main electronics**, 63, 64, 65, 68, 69, 78, 82, 121, 122
- maintenance, 64, 66, 70, 74, 77, 83, 99
- Maintenance, 64, 68, 70, 74, 75
- manual, 1, 34, 64, 69, 70, 76, 78, 85, 88, 120, 125
- mechanical, 63, 66, 68, 78, 85
- micro-controller, 79, 85

OUROBOROS

Microprocessor, 77, 78, 122

Modularity, 65, 68, 71, 74, 75

mouthpiece, 69, 70, 81

new, 33, 63, 67, 75, 91

O2 sensor, 48, 49, 50, 51

open circuit, 45, 46, 47, 52, 53

Operation, 70

Options, 36

Oxygen, 66, 68, 77, 78, 82, 83

PC, 41, 52, 53, 75, 83, 87, 88, 90,
93, 94, 121

PO2, 32, 34, 36, 42, 44, 45, 50, 51,
64, 65, 74, 75, 79, 81, 100, 121

primary, 75, 76, 79, 81, 87, 100

Redundancy, 65, 74, 75

Reliability, 63, 68, 74

Reprogram-ability, 65, 74, 75

Re-programming, 34, 87

Save Graph, 96

saved, 91, 93, 95, 96

secondary, 65, 77, 78, 82, 100

Simplicity of operation, 64, 68

software, 44, 65, 66, 68, 75, 77, 78,
79, 82, 83, 87, 122

Software, 76, 77, 79, 85

spreadsheets, 95

Sum, 22, 34, 57

Summary, 22, 34, 57, 121

System Block Diagram – Electronic
System, 84

System Block Diagram –
HP/Medium pressure Gas piping,
73

temperature, 61, 78, 82

Tissue state, 96

Turn On screen, 44

Upgradeability, 65, 74, 75

Utility, 98

valve, 32, 52, 54, 55, 69, 70, 77, 78,
80, 81, 82, 85, 120, 122

Vibration, 81

View Dives, 89, 94

VR3, 64, 65, 75, 77, 79, 121

Microsoft, Windows XP and Windows are registered trademarks of Microsoft Corporation

This manual, specifications and features of the Ouroboros Rebreather are proprietary and copyright Closed Circuit Research Ltd, 2003-2004. This document can not be copied or distributed without the prior agreement and authorization from Closed Circuit Research Ltd.

All information contained is subject to change. Contact the manufacturer for the latest information.

Also visit our website: www.ccrb.co.uk